

Stopper cylinder



TWG Series



Specification

Bore size(mm)	32	40	50
Fluid	Double acting type, Single acting-pull type		
Action	Air to be filtered by 40 μm filter element		
Operating pressure	Double acting type	0.15~1.0MPa(23~145psi)	
	Single acting-pull type	0.2~1.0MPa(28~145psi)	
Proof pressure	1.5MPa(215psi)		
Temperature °C	-20~80		
Range of stroke tolerance	+1 ^o		
Cushion type	Bumper		
Lubrication	Non required		
Mounting type	Flange(The mounting high can be changed)		
Stopper type	Round rod, Flat rod, Roller shock less stopper(with absorber)		
Port size 1)	1/8"		

① PT thread, NPT thread and G thread are available. Add) Refer to Page 403~426 for details of sensor switch.

Symbol



Product feature

- JIS standard is implemented.
- Widening the piston rod can effectively improve the impact resistance ability of the cylinder.
- The installation height is adjustable and several rod end modes can be selected. The cushion effect of the stopper cylinder with shock absorber is better.
- Shockless stopper cylinder is attached with self-lock device, which can prevent the returning of rebound of rocker caused by bar objects.
- Several series and specifications for stopper cylinders can be selected.

Ordering code

Model can to be changed Ordering code. Example:

Production type: TWG
 Magnet: With magnet
 Bore size: 50mm
 Stroke: 30mm
 Stopper: Shockless stopper(adjustble absorber)
 Self-lock function: With self-lock
 Thread type: NPT

Model: TWG-S-50 × 30-KF-T

Ordering code: TWG S 50 K F 0030 T

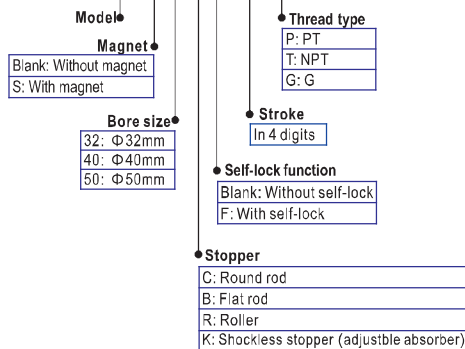

Example of model

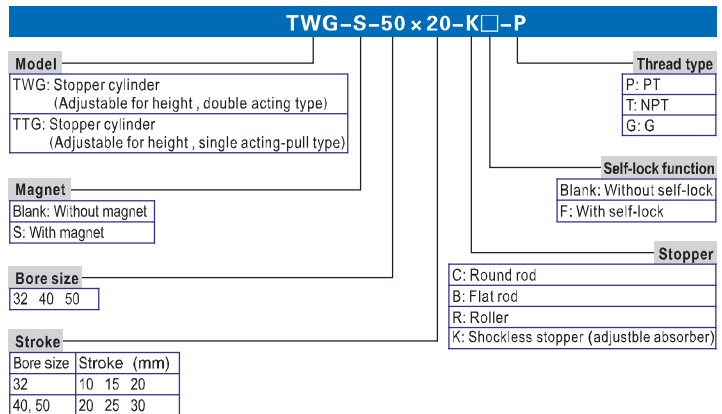

Lateral Load and Operation pressure

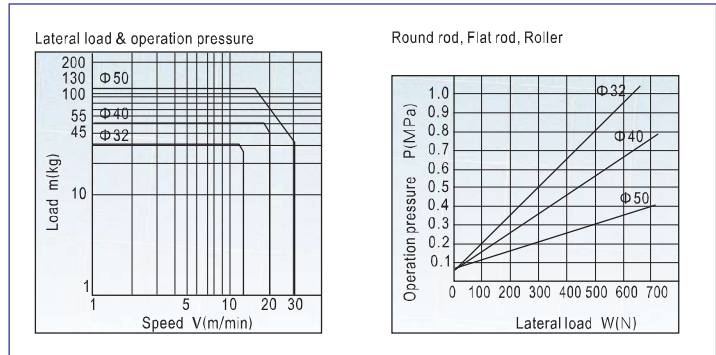

Stopper cylinder



TWG Series

Inner structure and material of major parts

TTG-K

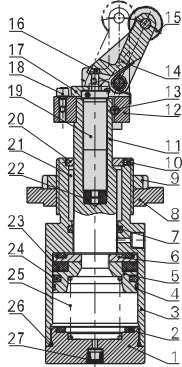

No.	Item	Material
1	Back cover	Aluminum alloy
2	Bumper	TPU
3	Body	Aluminum alloy
4	Wear ring	Wear resistant material
5	Piston	Aluminum alloy
6	Magnet washer	Aluminum alloy
7	Packing	NBR
8	Flange	Aluminum alloy
9	Fixed nut	Carbon steel
10	Countersink screw	Carbon steel
11	Piston rod	Carbon steel with 20 μ m chrome plated
12	Fixed seat	Nodular cast iron
13	Lock pin	Cast steel
14	Rocker	Cast steel
15	Roller	Mild steel
16	Steel ball	Stainless steel
17	Obstruct block	Powder metallurgy
18	Cancel cap	Aluminum alloy
19	Shock absorber	
20	Lock ring	Powder metallurgy
21	Sliding bushing	Wear resistant material
22	Absorber fix and adjust seat	POM
23	Magnet	Plastic
24	Piston seal	NBR
25	Spring	Spring steel
26	O-ring	NBR
27	Silence	Sintered bronze particle

Dimensions

Round rod(TWG-C, TTG-C)

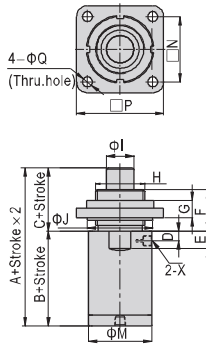

Bore size\Item	A	B	C	D	E	F	G	H
32	95	57	38	9	15	38	16	M36×1.5
40	100	62	38	12	16	38	16	M45×1.5
50	100	62	38	10	16	38	16	M45×1.5

Bore size\Item	I	J	M	N	P	Q	X
32	20	50	40	50	70	9	1/8"
40	25	60	47	60	80	9	1/8"
50	25	60	58	60	80	9	1/8"

Note: The type with magnet and the type without magnet have the same dimension.

Flat rod(TWG-B, TTG-B)

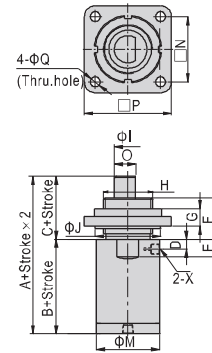

Bore size\Item	A	B	C	D	E	F	G	H
32	95	57	38	9	15	38	16	M36×1.5
40	100	62	38	12	16	38	16	M45×1.5
50	100	62	38	10	16	38	16	M45×1.5

Bore size\Item	I	J	M	N	O	P	Q	X
32	20	50	40	50	18.5	70	9	1/8"
40	25	60	47	60	22.5	80	9	1/8"
50	25	60	58	60	22.5	80	9	1/8"

Note: The type with magnet and the type without magnet have the same dimension.

Shockless stopper(TWG-K(F), TTG-K(F))

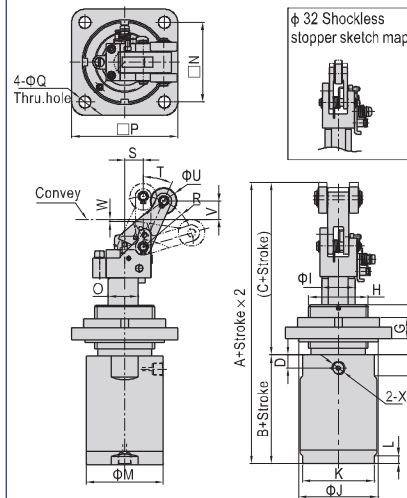

Bore size\Item	A	B	C	D	E	F	G	H
32	147.5	57	90.5	9	15	38	16	M36×1.5
40	172	62	110	12	16	38	16	M45×1.5
50	172	62	110	10	16	38	16	M45×1.5

Bore size\Item	I	J	K	L	M	N	O	P	Q
32	20	50	37	6	40	50	18.5	70	9
40	25	60	44	6	47	60	22.5	80	9
50	25	60	54	6	58	60	22.5	80	9

Bore size\Item	R	S	T	U	V	W	X
32	24.5	11.5	28	15	4.4	1	1/8"
40	38	14	24	20	14	1.6	1/8"
50	38	14	24	20	14	1.6	1/8"

Note: The type with magnet and the type without magnet have the same dimension.
The type with self-lock and the type without self-lock have the same dimension.

Roller(TWG-R, TTG-R)

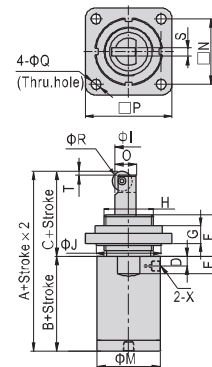

Bore size\Item	A	B	C	D	E	F	G	H	I
32	116	57	59	9	15	38	16	M36×1.5	20
40	123	62	61	12	16	38	16	M45×1.5	25
50	123	62	61	10	16	38	16	M45×1.5	25

Bore size\Item	J	M	N	O	P	Q	R	S	T	X
32	50	40	50	18.5	70	9	20	8	4	1/8"
40	60	47	60	22.5	80	9	20	8	4	1/8"
50	60	58	60	22.5	80	9	20	8	4	1/8"

Note: The type with magnet and the type without magnet have the same dimension.



TW



Stopper cylinder



TWG Series

■ Installation and application

1. Function & Operating Manual

The appearance of Stopper

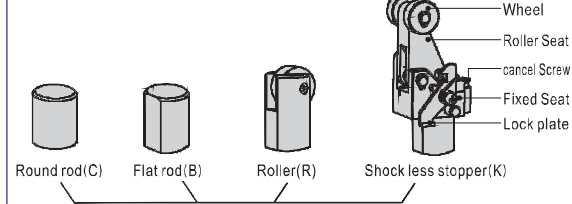

TWG Series appearance

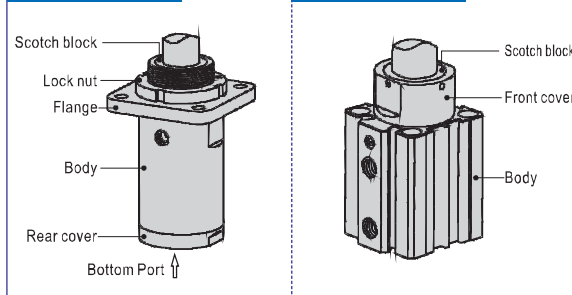

2. Adjustment of Shock Absorber

- 2.1) The Shock Absorber had been adjusted before the cylinder finished.
- 2.2) The client can adjust it if necessary.
- 2.3) The steps are as following.
 - a. Loose the fixed screw.
 - b. Turn the Shock Absorber to adjust the cushion ability.
 - c. Fasten the fixed screw.

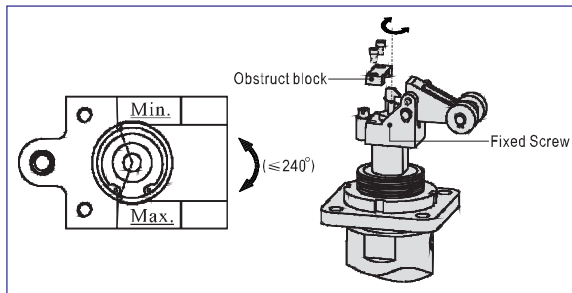

3. Multi-working position

- 3.1) If the body is fixed, just to adjust the scotch block, the working direction of the cylinder will be changed.
- 3.2) For TWG series, adjusting the position of flange can be changed the working height.

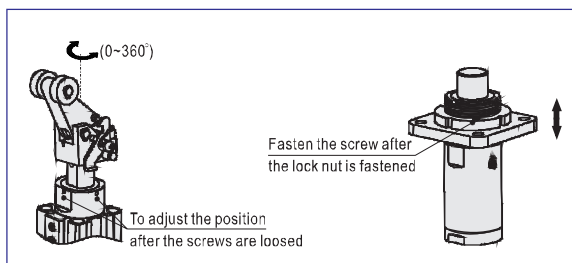

4. Working Forbidden(Shock less stopper(K))

- 4.1) This function is used to cancel the stop action of the cylinder, and make the work piece pass easy.
- 4.2) The steps are as following.
 - a. Screw off the cancel screw from the flange.
 - b. Put the roller seat down.
 - c. Fasten the cancel screw in the screw hole on the fixed seat and the tail of the cancel screw should be inserted in the hole made on the roller seat.

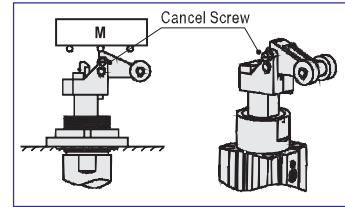

5. How to use stopper function

- 5.1) When the shock absorber is impacted deeply, added impact energy must be avoided. The cylinder without shock absorber can't be impacted by load, otherwise mechanical failure may be caused.
- 5.2) The maximum impact kinetic energy acting on the piston rod can't exceed the allowable maximum values, otherwise mechanical failure may be caused.

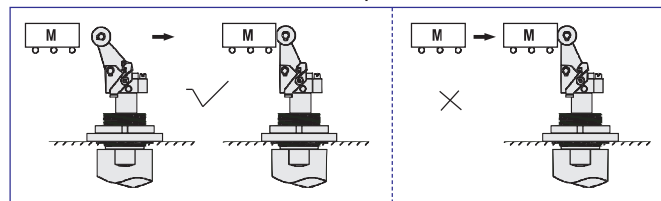

6. Self-locking

Usually, when the stopper cylinder is operating, work piece will be rebound as the effect of shocker absorber. In order to keep the work piece steady, we have developed this self-locking device.

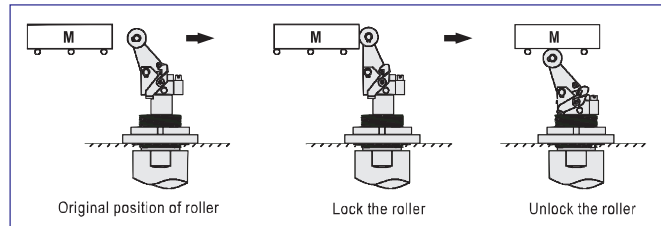

TW