



Tri-rod cylinder—TCL, TCM Series

Compendium of TCL/TCM Series

JIS standard

Two guides of special bearing steel
Steel ball linear bearing(TCL) or Bronze sliding bearing(TCM)

Double-rod guide unit
Two guides of special bearing steel and linear bearing or bronze bearing guide are used to prevent rotating. They can bear high torque and radial load.

Magnetic switch slots around the cylinder body
There are magnetic switch slots around the cylinder body convenient to install inducting switch.

Two groups of inlet and outlet air ports

Be mounted cylinder from three directions

Multi-type cylinder

TCL: Linear bearing

TCM: Bronze bearing

Twelve bore size are available
Bore size: 6, 10, 12, 16, 20, 25, 32, 40, 50, 63, 80, 100

Up inlet or outlet air port

Side inlet or outlet air port

Up mounted

Bottom mounted

Back mounted

Installation and application



1. When load changes in the work, the cylinder with abundant output capacity shall be selected.
2. Relative cylinder with high temperature resistance or corrosion resistance shall be chosen under the condition of high temperature or corrosion.
3. Necessary protection measure shall be taken in the environment with higher humidity, much dust or water drops, oil dust and welding dregs.
4. Dirty substances in the pipe must be cleared away before cylinder is connected with pipeline to prevent the entrance of particles into the cylinder.
5. The medium used by cylinder shall be filtered to 40 μm or below.
6. The cylinder shall avoid the influence of side load in operation to maintain the normal work of cylinder and extend the service life.
7. Anti-freezing measure shall be adopted under low temperature environment to prevent moisture freezing.
8. If the cylinder is dismantled and stored for a long time, please conduct anti-rust treatment to the surface. Anti-dust cap shall be inserted into the inlet and outlet ports. As the precision of the manufacture and guide is high, never dismantle the fixed block or cylinder cover without permission.



Tri-rod cylinder

TCL,TCM Series



Symbol

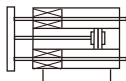

Product feature

- JIS standard is implemented.
- Two guides of special bearing steel and linear bearing or bronze bearing guide are used to prevent rotating. They can bear high torque and radial load.
 - ★Note: Steel ball linear bearing: It is suitable for elevation action of cylinder or the situation requiring high precision and high bearing ability, especially for the situation requiring low fraction action process.
 - Bronze sliding bearing: it is suitable for the action that has radial load resistance. Compared with normal cylinder of same use, the horizontal impact resistance is doubled and it has stronger torsion rigidity.
- Drive unit and guide unit are in the same barrel that no additional accessories are needed with minimal space required. The air intake is optional and it is convenient to install.
- The bottom, back side and fixing plate of main body respectively has two exact orientation orifices (See ΦPA orifice and the orifice in XX point), which can provide orientation installation with high precision for the special situation.
- Options of switch mounting with provision 4 mounting slots.
- Special design of main body provides multi-mount;

Ordering code

TC M 50×50 S G					
① Model		② Bearing type		③ Bore size	
TC: Tri-rod cylinder (Double acting type)	M: Bronze bearing	6	Refer to stroke table for details	S: With magnet	G: G
		10			
		12			
		16			
		20			
		25			
	L: Linear bearing M: Bronze bearing	32			
		40			
		50			
		63			
		80			
		100			

[Note1] TC Series are all with magnet. [Note2] When the thread is standard, the code is blank.

Specification

Bore size (mm)	6	10	12	16	20	25	32	40	50	63	80	100
Acting type	Double acting											
Fluid	Air(to be filtered by 40 μm filter element)											
Operating pressure	0.15~0.7MPa(22~100psi)						0.15~1.0MPa(22~145psi)					
Proof pressure	1.2MPa(175psi)						1.5MPa(215psi)					
Temperature °C	-20~70											
Speed range mm/s	50~500						30~500			50~400		
Stroke tolerance	≤100 ^{+1.0} ₀ >100 ^{+1.5} ₀											
Cushion type	Bumper											
Non-rotating tolerance [Note1]	TCL	-		±0.08°	±0.07°	±0.06°	±0.05°	±0.04°				
	TCM	±0.1°		±0.10°	±0.09°	±0.08°	±0.06°	±0.05°				
Port size [Note2]	M3×0.5			M5×0.8			1/8"		1/4"		3/8"	

[Note1] Retract position.

[Note2]G thread is available.

Add) Refer to P451 for detail of sensor switch.

Stroke

Bore size (mm)	Standard stroke (mm)											Max.std stroke						
6	5	10	15	20									20					
10	5	10	15	20	25	30						30						
12	10	20	25	30	40	50	60	70	75	80	90	100	125	150	150			
16	10	20	25	30	40	50	60	70	75	80	90	100	125	150	175	200	200	
20 25	20	25	30	40	50	60	70	75	80	90	100	125	150	175	200	225	250	250
32 40 50 63	25	30	40	50	60	70	75	80	90	100	125	150	175	200	225	250	250	
80 100	25	30	40	50	60	70	75	80	90	100	125	150	175	200	225	250	250	

[Note] When the discrepancy between non-standard stroke and standard stroke is 1~5mm, The dimensions of non-std stroke cylinder has the same dimensions as the next longer stroke std. stroke cylinder. e.g. 86mm stroke cylinder has the same dimensions of 90 std. stroke cylinder. But 84mm stroke cylinder should be ordered by non-standard stroke.

Tri-rod cylinder

TCL, TCM Series

How to mount

Fixation of screw on top surface($\Phi 6\sim\Phi 100$)

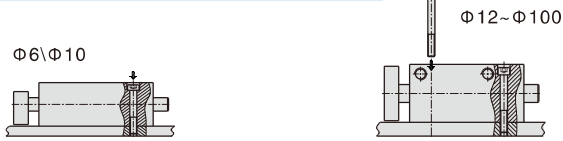

Fixation of screw at back side($\Phi 6\sim\Phi 100$)

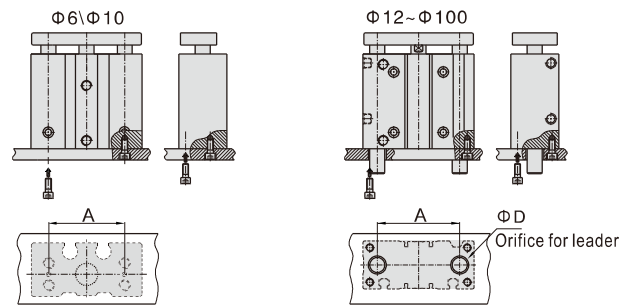

Fixation of screw at bottom surface($\Phi 12\sim\Phi 100$)

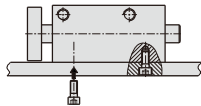

Fixation of T slot at bottom($\Phi 12\sim\Phi 100$)

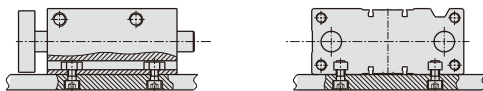

Bore size\Item	6	10	12	16	20	25	32	40	50	63	80	100
A	20.5	23	41	46	54	64	78	86	110	124	156	188
D (Min)	TCM	X	X								30	32
	TCL	-	-	8	10	12	14	18	18	22	22	25

Safe load and torque

Bore size	Type	Stroke(mm)																			
		5	10	15	20	25	30	40	50	60	70	75	80	90	100	125	150	175	200	225	250
Max. safe load		Unit: Newton(N)																			



12	TCM	-	44	-	33	29	26	41	36	30	28	26	25	24	22	19	17	-	-	-	-
	TCL	-	37	-	27	25	22	35	30	27	24	23	21	19	18	15	12	-	-	-	-
16	TCM	-	67	-	51	42	37	63	58	49	41	37	35	33	32	27	24	22	20	-	-
	TCL	-	54	-	40	37	32	54	47	42	38	35	32	30	28	23	20	17	15	-	-
20	TCM	-	-	-	78	61	57	123	112	99	91	67	84	79	75	66	59	54	49	45	42
	TCL	-	-	-	58	52	48	101	90	83	74	70	69	63	58	62	54	48	43	39	35
25	TCM	-	-	-	93	89	76	142	131	119	107	101	97	90	85	68	79	71	65	61	55
	TCL	-	-	-	82	79	68	132	118	109	99	93	88	81	77	80	70	62	55	50	45
32	TCM	-	-	-	-	203	190	179	164	221	197	182	172	163	157	142	127	116	106	98	91
	TCL	-	-	-	-	191	182	166	157	207	178	164	156	150	144	203	186	171	158	146	137
40	TCM	-	-	-	-	203	190	179	164	221	197	182	172	163	159	142	127	116	106	97	91
	TCL	-	-	-	-	190	182	166	157	210	179	163	156	150	144	203	185	171	158	146	137
50	TCM	-	-	-	-	296	283	268	245	303	288	273	266	253	241	216	195	179	164	155	142
	TCL	-	-	-	-	208	196	185	173	259	232	223	212	207	199	264	242	224	207	195	181
63	TCM	-	-	-	-	296	283	268	245	303	288	273	266	253	241	216	195	179	164	153	142
	TCL	-	-	-	-	206	196	180	171	259	232	221	212	205	196	262	240	221	205	191	178

Max. safe torque		Unit: Newton · Meter(N · m)																			
-------------------------	--	------------------------------------	--	--	--	--	--	--	--	--	--	--	--	--	--	--	--	--	--	--	--

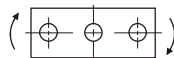

12	TCM	-	0.90	-	0.79	0.71	0.65	0.77	0.72	0.65	0.53	0.50	0.47	0.41	0.36	0.31	0.27	-	-	-	-
	TCL	-	0.61	-	0.45	0.40	0.35	0.58	0.50	0.44	0.39	0.37	0.35	0.32	0.29	0.24	0.20	-	-	-	-
16	TCM	-	1.21	-	1.04	0.94	0.88	1.23	1.11	0.99	0.72	0.69	0.65	0.61	0.58	0.50	0.44	0.40	0.36	-	-
	TCL	-	0.99	-	0.74	0.66	0.59	0.99	0.86	0.77	0.69	0.65	0.61	0.57	0.52	0.43	0.37	0.32	0.28	-	-
20	TCM	-	-	-	1.57	1.42	1.31	2.39	2.15	1.97	1.90	1.88	1.86	1.72	1.63	1.44	1.28	1.16	1.06	1.01	0.90
	TCL	-	-	-	1.26	1.14	1.03	2.17	1.94	1.79	1.59	1.52	1.46	1.33	1.25	1.34	1.17	1.03	0.93	0.88	0.76
25	TCM	-	-	-	2.40	2.22	2.01	3.66	3.35	3.17	3.06	2.96	2.91	2.77	2.57	2.26	2.02	1.83	1.67	1.57	1.42
	TCL	-	-	-	2.11	1.96	1.75	3.37	3.02	2.71	2.42	2.38	2.33	2.19	1.97	2.05	1.78	1.58	1.41	1.22	1.16
32	TCM	-	-	-	-	6.35	6.00	5.73	5.13	5.98	5.74	5.69	5.62	5.11	4.97	4.42	3.98	3.61	3.31	2.97	2.84
	TCL	-	-	-	-	5.95	5.73	5.44	4.89	5.43	5.15	5.11	5.02	4.70	4.51	6.34	5.79	5.33	4.93	4.33	4.29
40	TCM	-	-	-	-	7.00	6.60	6.11	5.66	6.66	6.31	6.27	6.23	5.86	5.48	4.78	4.38	3.98	3.65	3.34	3.13
	TCL	-	-	-	-	6.55	6.21	5.77	5.39	6.17	5.67	5.62	5.58	5.33	4.96	6.98	6.38	5.87	5.43	5.00	4.72
50	TCM	-	-	-	-	13.00	12.60	11.00	10.80	13.70	12.70	12.00	11.80	11.10	10.80	9.50	8.60	7.86	7.24	6.80	6.24
	TCL	-	-	-	-	9.17	8.75	8.30	7.62	10.30	9.94	9.83	9.77	8.82	8.74	11.60	10.70	9.83	9.12	8.95	7.95
63	TCM	-	-	-	-	14.70	13.60	12.90	12.10	19.40	16.20	13.50	12.70	12.10	11.90	10.70	9.69	8.86	8.16	7.52	7.04
	TCL	-	-	-	-	10.20	9.74	9.20	8.48	17.50	14.00	11.00	10.60	10.20	9.74	13.00	11.90	11.00	10.20	9.63	8.84
80	TCM	-	-	-	-	21.9	20.8	19.7	18.6	15.8	24	22.9	21.7	21	20.5	18.6	17	15.6	14.5	13.5	12.6
	TCL	-	-	-	-	15.1	14.3	13.6	12.9	12.2	23.8	22.7	21.6	21	20.6	18.9	17.3	16	14.8	13.5	12.9
100	TCM	-	-	-	-	38.8	36.8	35.0	33.5	28.5	39.4	37.5	35.6	34.5	33.8	30.9	28.4	26.2	24.4	22.5	21.4
	TCL	-	-	-	-	27.1	25.7	24.4	23.6	26	39.8	37.9	36	35.2	34.6	31.8	29.3	27.2	25.3	23.5	22.1

Tri-rod cylinder

TCL,TCM Series

Inner structure and material of major parts

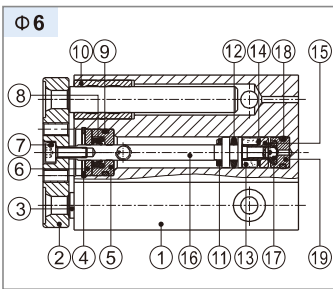

NO.	Item	NO.	Item
1	Body	11	Bumper
2	Fixing plate	12	Piston seal
3	Leader	13	Magnet
4	C clip	14	Magnet washer
5	Front cover	15	Piston
6	O-ring stop block	16	Piston rod
7	Screw	17	Bumper
8	Piston rod O-ring	18	O-ring
9	O-ring	19	Washer
10	Bearing		stop block

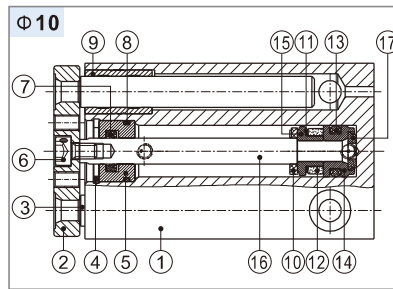

NO.	Item	NO.	Item
1	Body	10	Bumper
2	Fixing plate	11	Magnet washer
3	Leader	12	Magnet
4	C clip	13	Piston seal
5	Front cover	14	Piston
6	Screw	15	Magnet holder
7	Piston rod O-ring	16	Piston rod
8	O-ring	17	Bumper
9	Bearing		

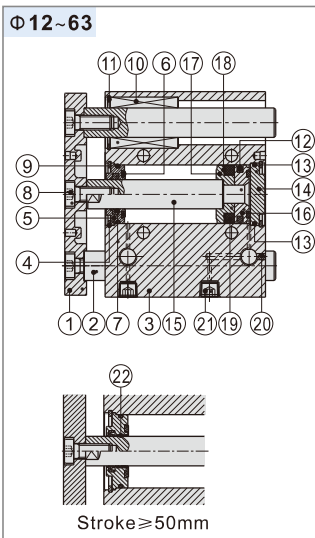

TCL

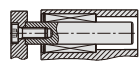

Bore size $\Phi 12$ 、 $\Phi 16$ mm
Stroke ≤ 30 mm

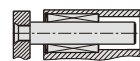

Bore size $\Phi 20 \sim \Phi 63$ mm
Stroke ≤ 50 mm

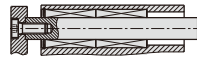

Bore size $\Phi 12$ 、 $\Phi 16$ mm
30 < Stroke ≤ 100 mm

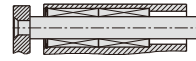

Bore size $\Phi 20 \sim \Phi 63$ mm
50 < Stroke ≤ 100 mm



Bore size $\Phi 12$ 、 $\Phi 16$ mm
Stroke > 100mm

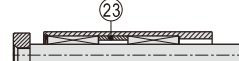

Bore size $\Phi 20 \sim \Phi 63$ mm
Stroke > 100mm

TCM

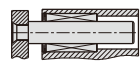

Bore size $\Phi 12 \sim \Phi 25$ mm
Stroke ≤ 50 mm

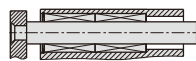

Bore size $\Phi 12 \sim \Phi 63$ mm
50 < Stroke ≤ 100 mm

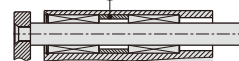

Bore size $\Phi 12 \sim \Phi 63$ mm
Stroke > 100mm

NO.	Item	NO.	Item
1	Fixing plate	13	O-ring
2	Leader	14	Back cover
3	Body	15	Piston rod
4	C clip	16	Piston
5	Front cover	17	Magnet holder
6	Bumper	18	Magnet washer
7	Piston rod O-ring	19	Magnet
8	Screw	20	Screw
9	O-ring	21	Screw
10	Bearing	22	Bearing
11	C clip	23	Spacer
12	Piston seal		

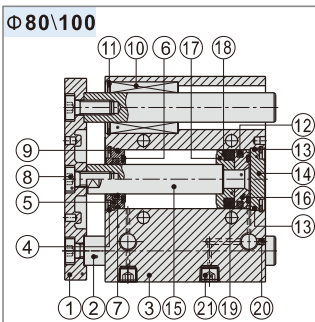

TCL

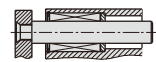

Stroke S=25~60mm

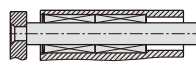

Stroke S=70~150mm



Stroke S=175~250mm

TCM



Stroke S=25~250mm

NO.	Item	NO.	Item
1	Fixing plate	12	Piston seal
2	Leader	13	O-ring
3	Body	14	Back cover
4	C clip	15	Piston rod
5	Front cover	16	Piston
6	Bumper	17	Magnet holder
7	Piston rod O-ring	18	Magnet washer
8	Screw	19	Magnet
9	O-ring	20	Screw
10	Bearing	21	Screw
11	C clip	22	Spacer

Dimensions

TCM6\TCM10

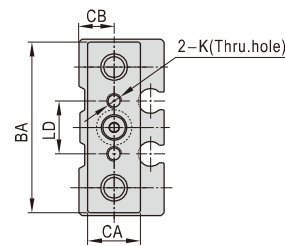
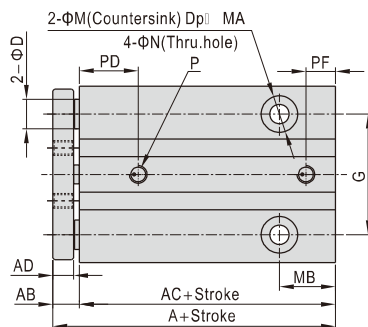
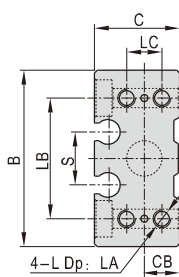

Bore size\Item	A	AB	AC	AD	B	BA	C	CA	CB	D	G	K	L	LA	LB	LC	LD	M	MA	MB	N	P	PD	PF
6	29.5	6	23.5	5	30	29	14.5	9	6	5	20.5	M2.5X0.45	M3X0.5	5	20.5	6	9	6	3	9.5	3.5	M3X0.5	9.5	5.5
10	32	6	26	5	34	33	18	10	7.5	6	23	M3X0.5	M4X0.7	5	23	8	11	8	4	8.5	4.5	M3X0.5	11.5	5

Tri-rod cylinder

TCL,TCM Series

TCL/TCM12~63

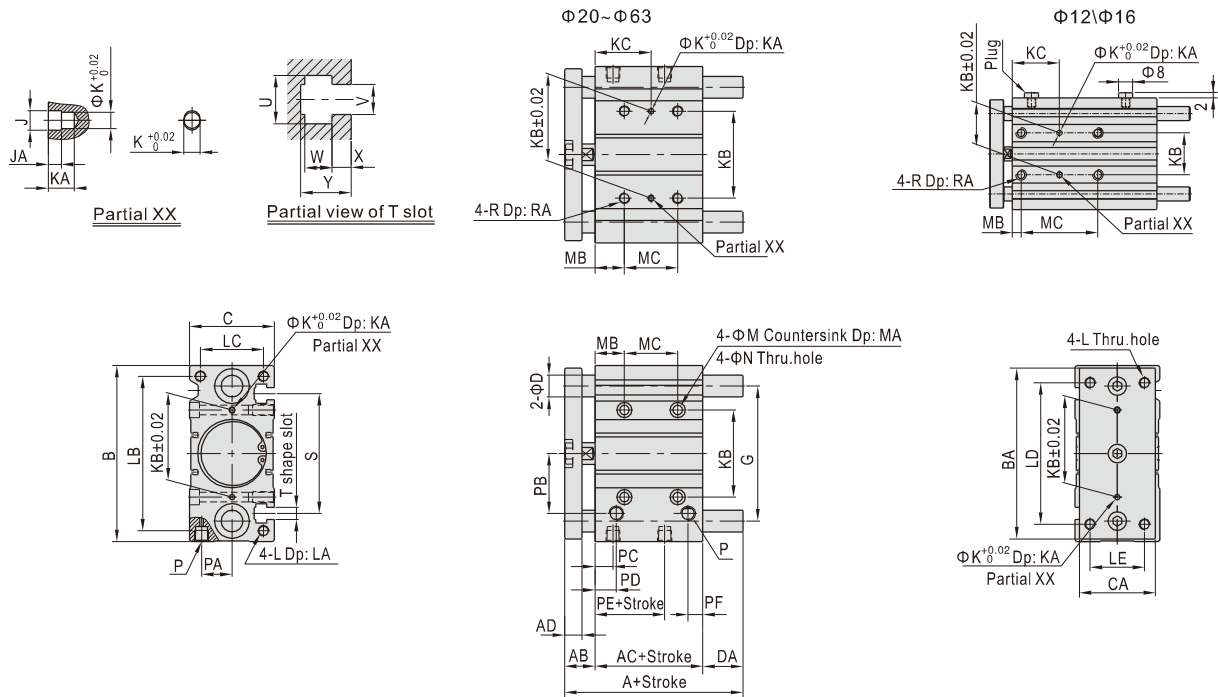

Bore size\Item	A				DA				MC				KC								
	TCL	TCM	TCL	TCM	TCL	TCM	TCL	TCM	≤30	31~100	101~200	>200	≤30	31~100	101~200	>200					
Stroke	≤30	≤50	31~100	101~200	>200	≤30	31~100	101~200	>200	≤50	51~100	101~200	>200	≤40	41~100	101~200	>200	≤40	41~100	101~200	>200
12	42	55	85	-	0	13	43	-	0	13	43	-	20	40	110	-	15	25	60	-	
16	46	65	95	-	0	19	49	-	0	19	49	-	24	44	110	-	17	27	60	-	
20	53	80	104	122	0	27	51	69	0	27	51	69	24	44	120	200	29	39	77	117	
25	53.5	82	104.5	122	0	28.5	51	68.5	0	28.5	51	68.5	24	44	120	200	29	39	77	117	
Stroke	≤50	≤50	51~100	101~200	>200	≤50	51~100	101~200	>200	≤50	51~100	101~200	>200	≤40	41~100	101~200	>200	≤40	41~100	101~200	>200
32	65	78	102	118	140	5.5	42.5	58.5	80.5	18.5	42.5	58.5	80.5	24	48	124	200	33	45	83	121
40	66	78	102	118	140	0	36	52	74	12	36	52	74	24	48	124	200	34	46	84	122
50	76	89	118	134	161	4	46	62	89	17	46	62	89	24	48	124	200	36	48	86	124
63	77	89	118	134	161	0	41	57	84	12	41	57	84	28	52	128	200	38	50	88	124
Bore size\Item	AB	AC	AD	B	BA	C	CA	D(TCL)	D(TCM)	G	J	JA	K	KA	KB	L	LA	LB	LC	LD	
12	13	29	8	58	56	26	22	6	8	41	3.5	3	3	6	23	M4×0.7	10	50	18	48	
16	13	33	8	64	62	30	25	8	10	46	3.5	3	3	6	24	M5×0.8	12	56	22	54	
20	16	37	10	83	81	36	30	10	12	54	3.5	3	3	6	28	M5×0.8	13	72	24	70	
25	16	37.5	10	93	91	42	38	12	16	64	4.5	3	4	6	34	M6×1.0	15	82	30	78	
32	22	37.5	12	112	110	48	44	16	20	78	4.5	3	4	6	42	M8×1.25	20	98	34	96	
40	22	44	12	120	118	54	44	16	20	86	4.5	3	4	6	50	M8×1.25	20	106	40	104	
50	28	44	16	148	146	64	60	20	20	110	6	4	5	8	66	M10×1.5	22	130	46	130	
63	28	49	16	162	158	78	70	20	20	124	6	4	5	8	80	M10×1.5	22	142	58	130	
Bore size\Item	LE	M	MA	MB	N	P	PA	PB	PC	PD	PE	PF	R	RA	S	U	V	W	X	Y	
12	14	8	4.5	5	4.5	M5×0.8	8	18	11	11	13	7.5	M5×0.8	10	37	7.5	4.5	4	2	6.5	
16	16	8	4.5	5	4.5	M5×0.8	10	19	11	11	15	8	M5×0.8	10	38	7.5	4.5	4	2.5	7	
20	18	9.5	5.5	17	5.5	1/8"	10.5	25	10.5	10.5	12.5	9	M6×1.0	12	44	8.5	5.5	4.5	3	8	
25	26	9.5	5.5	17	5.5	1/8"	13.5	28.5	11.5	11.5	12.5	9	M6×1.0	12	50	8.5	5.5	4.5	3	8.5	
32	30	11	7.5	21	6.5	1/8"	15	34	12.5	12.5	7	9	M8×1.25	16	63	10.5	6.5	5.5	3.5	9.5	
40	30	11	7.5	22	6.5	1/8"	18	38	14	14	13	10	M8×1.25	16	72	10.5	6.5	5.5	4	11	
50	40	14	9	24	8.5	1/4"	21.5	47	12	14	9	11	M10×1.5	20	92	13.5	8.5	7.5	4.5	13.5	
63	50	14	9	24	8.5	1/4"	28	55	16.5	16.5	14	13.5	M10×1.5	20	110	18	11	10	7	18.5	

Tri-rod cylinder

TCL, TCM Series

TCL/TCM80

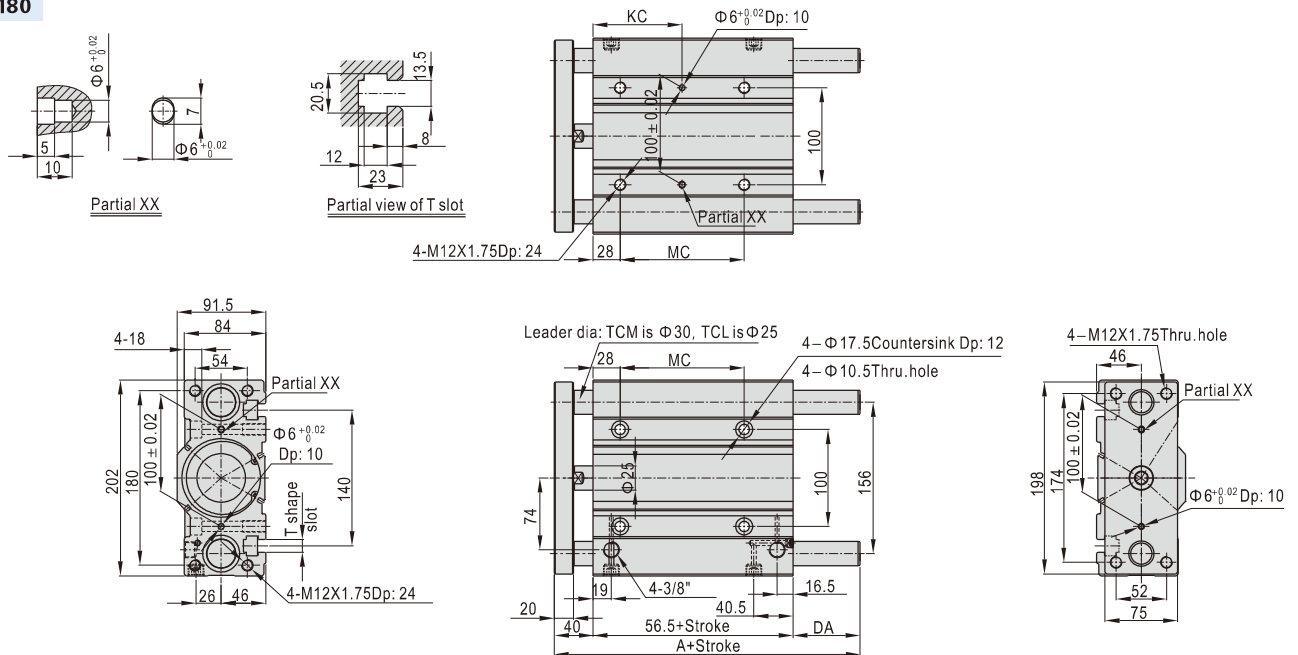

Item\Stroke	25	30	40	50	60	70	75	80	100	125	150	175	200	225	250
A	TCM=112.5/TCL=106.5					165.5					187.5				
DA	TCM=16/TCL=10					69					91				
KC	42					54					92				
MC	28					52					128				

TCL/TCM100

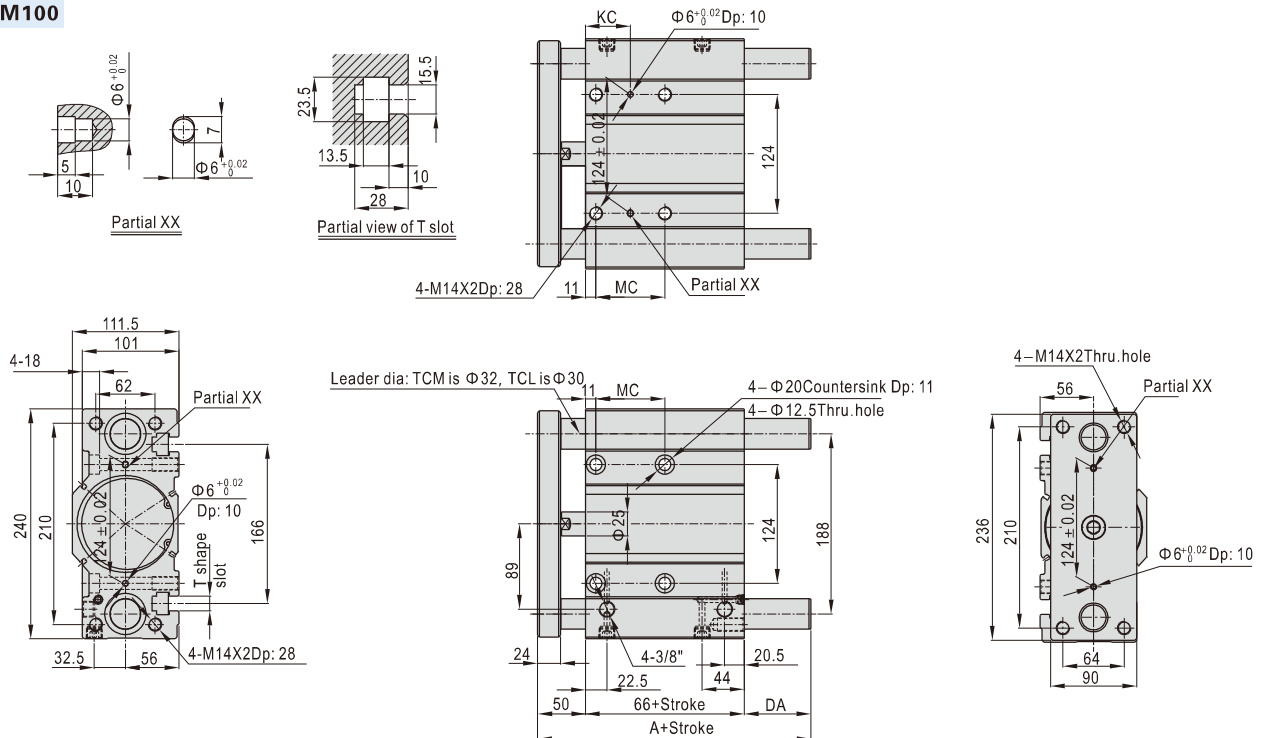

Item\Stroke	25	30	40	50	60	70	75	80	100	125	150	175	200	225	250
A	TCM=128/TCL=122					186					208				
DA	TCM=12/TCL=6					70					92				
KC	35					47					85				
MC	48					72					148				