

S45



HIGH PERFORMANCE EUROPEAN STYLE MINIATURE SENSOR ALL-IN-ONE FAMILY



- Red LED and Laser emissions
- Precise risk free laser class 1 emission
- Diffused LED proximity 800mm
- Background Suppression 400mm
- Retroreflective Class 1 Laser 15m/Red LED 7m
- Through beam Class 1 Laser 20m/Red LED 15m
- IP69K housing
- 2m Cable or metal M8 4 pole version
- PNP or NPN output with remote teach in input
- High speed RGB and white emission contrast sensor
- High precision distance sensor up to 200 mm



APPLICATIONS

- Processing and Packaging machinery
- Cosmetic and Pharmaceutical industry
- Electronics assembling
- Conveyor lines, material handling
- Automotive industry
- Print and paper industry
- Small part detection with maximum accuracy

S45		
Through beam	20m. (Laser Class1) 15m. (Red Led)	
Polarized Retroreflective	15m. (Laser Class1) 7m. (Red Led)	
Autocollimated Retroreflective for Transparent objects	2m. (Red Led)	
Autocollimated Retroreflective	2m. (Red Led)	
Diffused proximity	250mm. (Laser Class1) 800mm. (Red Led)	
Background suppressor	120mm. (Laser Class 1) 200mm. (Red Led) 400mm. (Red Led)	
Distance sensor	80mm. (Red Led) 200mm. (Red Led)	
Contrast Sensor	12mm. (White) 12mm. (RGB)	
Power Supply	Vdc	10...30Vdc
	Vac	(13...30Vdc Y models)
	Vac/Vdc	
Output	PNP	•
	NPN	•
	NPN/PNP	
	relay	
	other	Push Pull (Wxx, Yxx), Analog 0...10 V (Yxx)
Connection	cable	•
	connector	•
	pig-tail	
Approximate dimensions (mm)	34mm. x 20mm. X 12mm.	
Housing material	ABS(Housing), PMMA (Optics)	
Mechanical protection	IP67 & IP69K	

TECHNICAL DATA

Power supply	10...30Vdc (13...30Vdc Y models)
Ripple	10% max.
Consumption (Load current excluded)	≤ 30 mA
Light emission	Red LED 632 nm, Red Laser 650 nm
Setting	Push Button TEACH-IN
Indicators	LED Green Operating Volatage LED Yellow Output Status
Output	NPN, PNP, Push Pull (Wxx, Yxx), Analog 0...10 V (Yxx)
Output current	100 mA
Saturation voltage	2 V max
Response time	500 μs 333 μs (C03 Laser) 250 μs (F/G Laser) 50 μs (W03, W33) 20 μs (W13, W43)
Switching frequency	≤ 1000Hz ≤ 1500Hz (C03 Laser) ≤ 2000 Hz (F/G Laser) ≤ 10 kHz (W03, W33) ≤ 25 kHz (W13, W43)
Connection	Plastic M8 4-pole connector, Metal M8 4-pole connector 2 m cable
Dielectric strength	500 Vac, 1min between electronic and housing
Insulating resistance	>20M OHM, 500 Vdc between electronic and housing
Electrical protection	class 2
Mechanical protection	IP67 & IP69K
Ambient light rejection	according to EN 60947-5-2
Vibrations	0,5mm amplitude, 10...55Hz frequency , for every axis (EN60068-2-6)
Shock resistance	11 ms (30G) 6 shock for every axis (EN60068-2-27)
Housing material	ABS
Lens material	PMMA
Operating temperature	-20...+60 °C
Storage temperature	-20...+80 °C
Weight	10g. with connector, 40g. with cable

DIMENSIONS

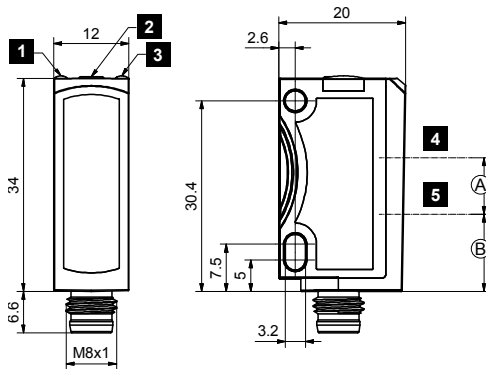

	S45-PR-2(5)-M03 S45-PR-5-Y03	S45-PR-2(5)-M13 S45-PR-5-Y13	S45-PR-2(5)-C03 S45-PR-B03	S45-PH-5-M03	S45-PH-5-C03 S45-PH-B03	S45-PR-G00	S45-PH-G00	S45-PR(PH)-F03
A	9	11.75	10.8	8.8	8.8	11.5	13.5	
B	12.3	11	11.5	12.5	13.5			22.3

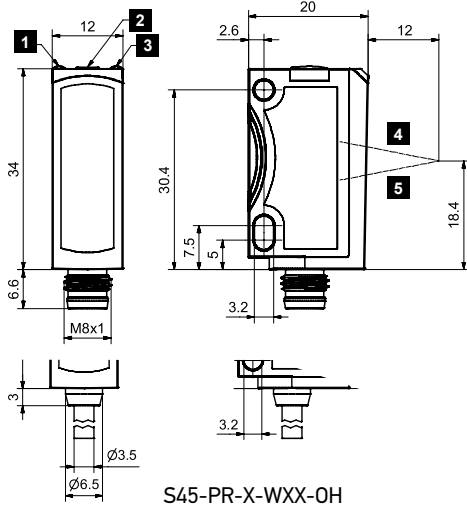

S45-PR-X-WXX-OH

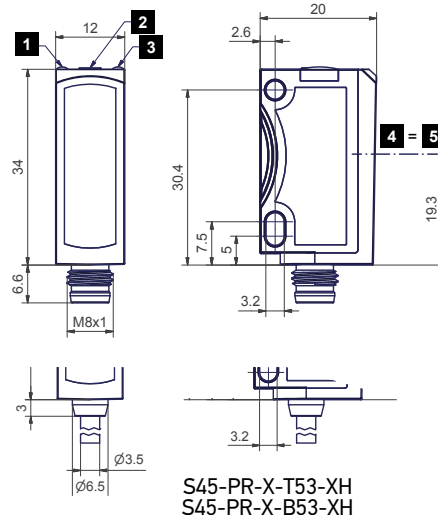

S45-PR-X-T53-XH
S45-PR-X-B53-XH

1	Yellow LED 1)
2	Button
3	Green LED 2)
4	Receiver axis
5	Emitter axis

1) switching output indicator
2) operating voltage indicator

CONNECTIONS

CABLE

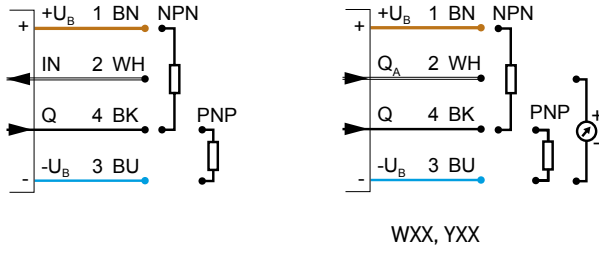

M8 CONNECTOR

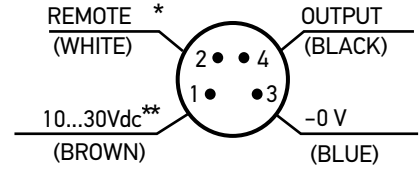

* Analog out YXX

** 13...30Vdc Y models

INDICATORS AND SETTINGS

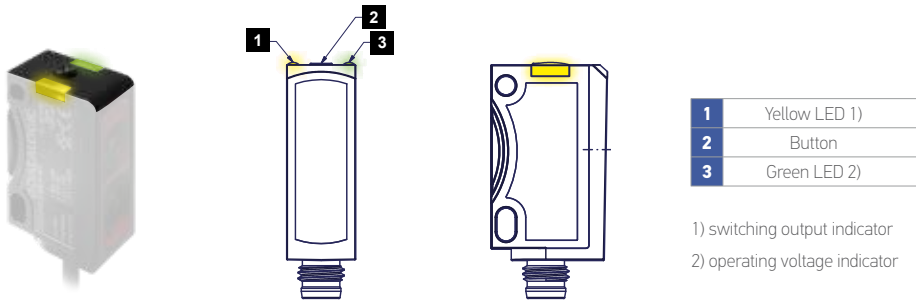

DETECTION DIAGRAMS

BACKGROUND SUPPRESSOR

DETECTION SPOT SIZE

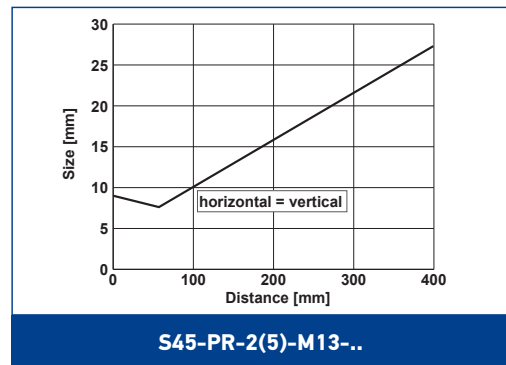
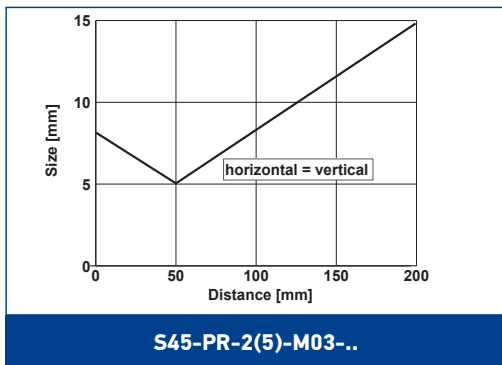

B/W SHIFT

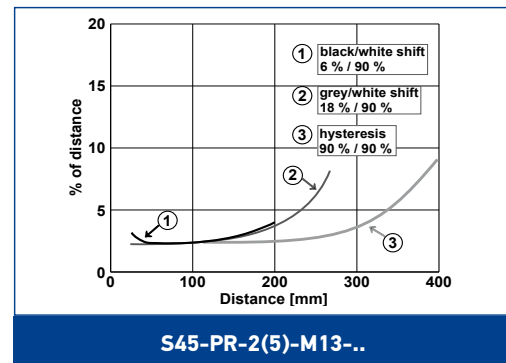
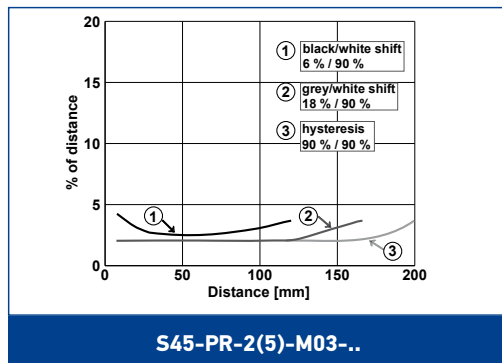

ENERGETIC DIFFUSED

DETECTION SPOT SIZE

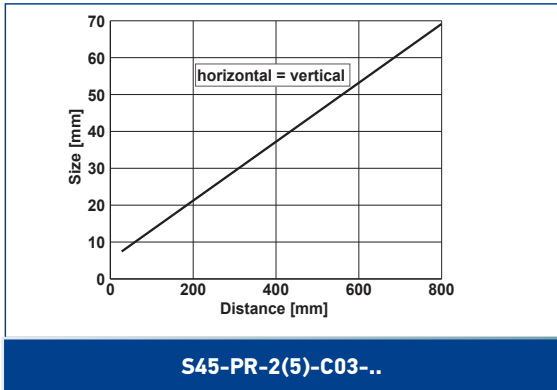

EXCESS GAIN

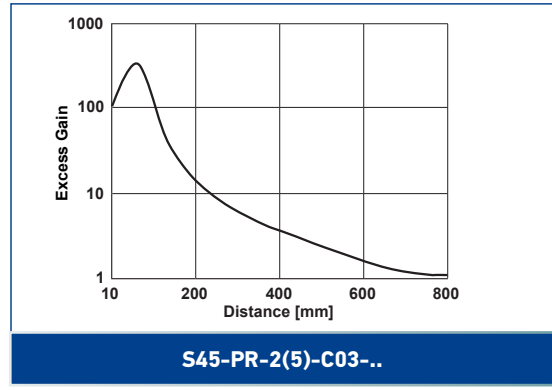

RETROREFLECTIVE POLARIZED

DETECTION SPOT SIZE

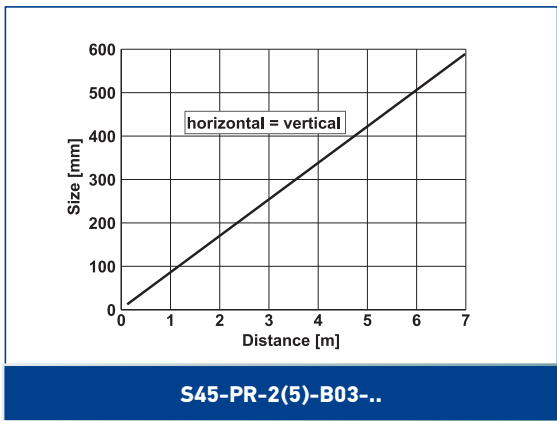

EXCESS GAIN

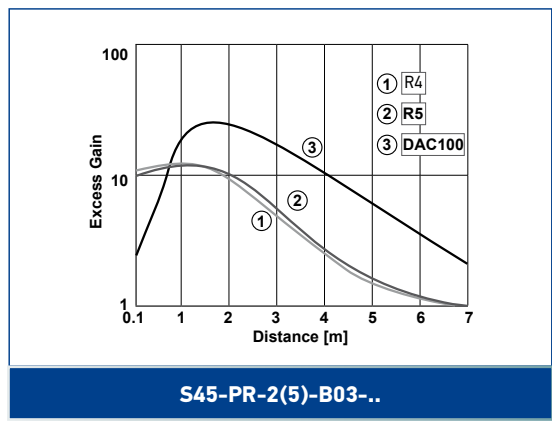

COAXIAL RETROREFLECTIVE POLARIZED

DETECTION SPOT SIZE

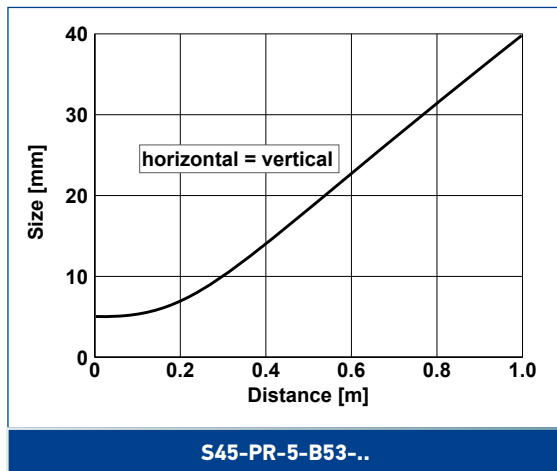

RETROREFLECTIVE FOR TRANSPARENT

DETECTION SPOT SIZE

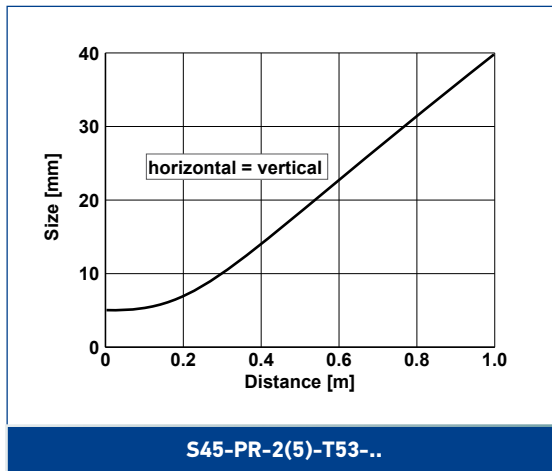

THROUGH BEAM

DETECTION SPOT SIZE

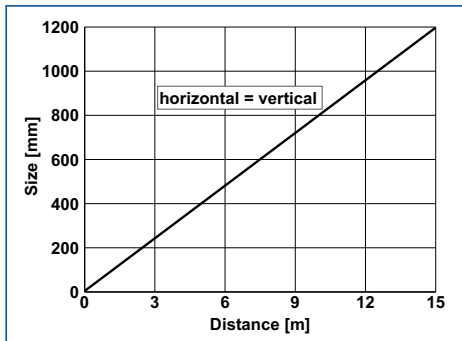

S45-PR-2(5)-F03-../S45-PR-2(5)-G00-XE

EXCESS GAIN

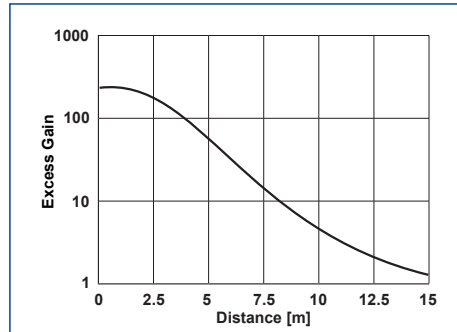

S45-PR-2(5)-F03-../S45-PR-2(5)-G00-XE

LASER BACKGROUND SUPPRESSOR

DETECTION SPOT SIZE

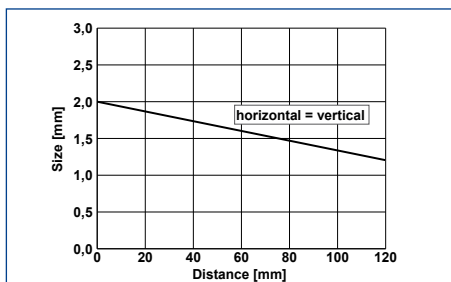

S45-PH-5-M03-..

B/W SHIFT

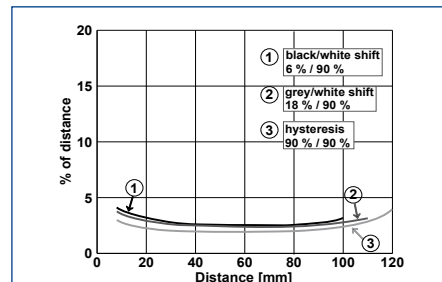

S45-PH-5-M03-..

LASER ENERGETIC DIFFUSED

DETECTION SPOT SIZE

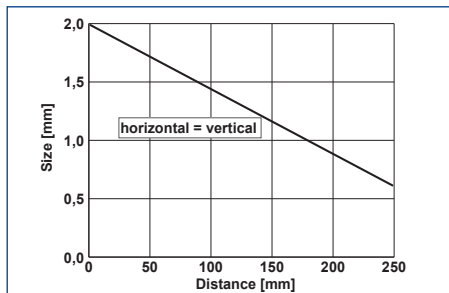

S45-PH-5-C03-..

EXCESS GAIN

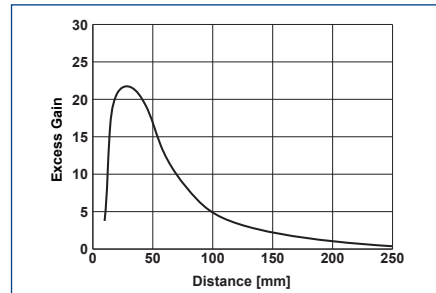

S45-PH-5-C03-..

LASER RETROREFLECTIVE POLARIZED

DETECTION SPOT SIZE

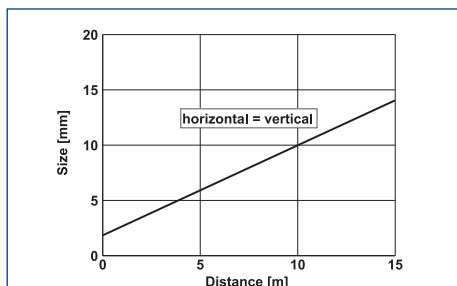

S45-PH-5-B03-..

EXCESS GAIN

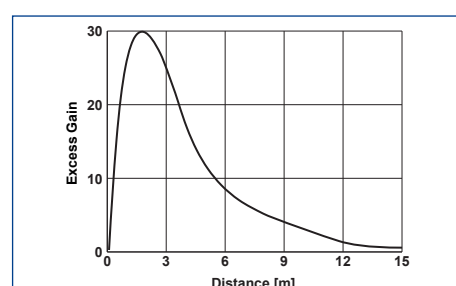

S45-PH-5-B03-..

LASER THROUGH BEAM

DETECTION SPOT SIZE

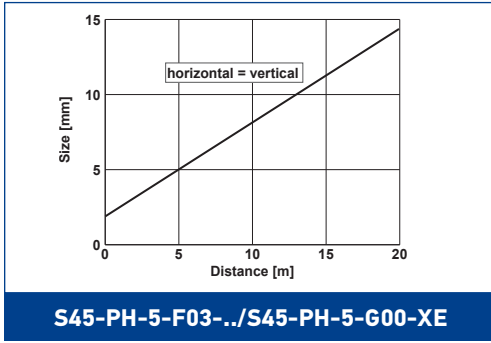

EXCESS GAIN

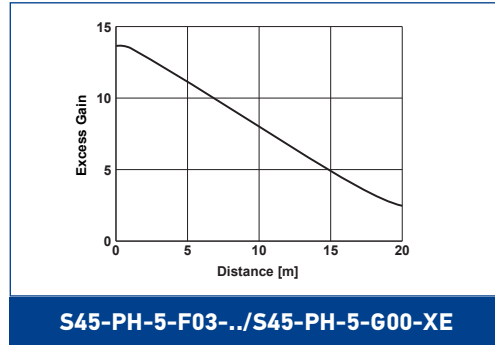

CONTRAST SENSOR

READING DIAGRAM

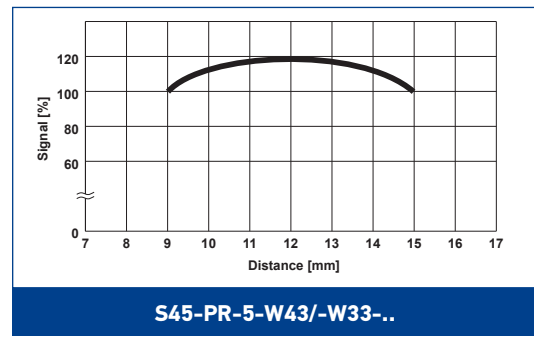
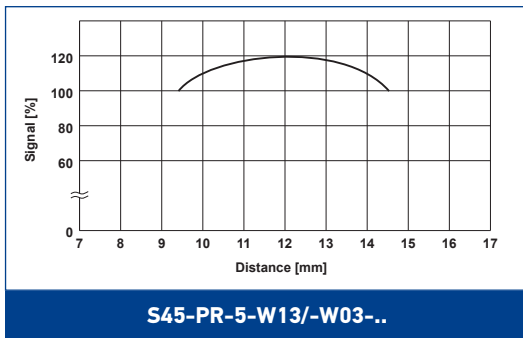

DISTANCE SENSOR

DETECTION SPOT SIZE

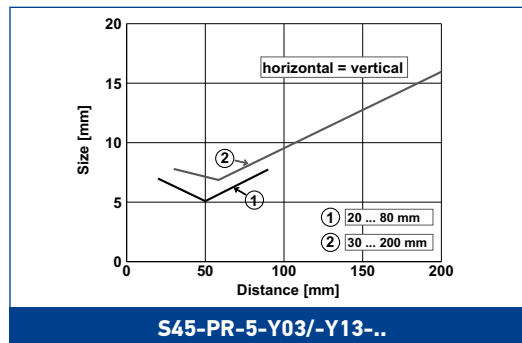

READING DIAGRAM

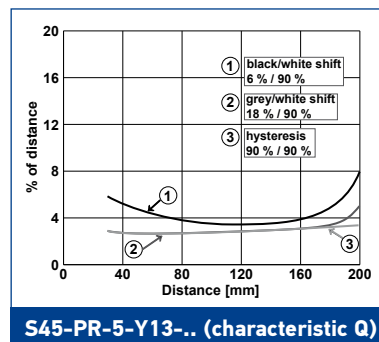
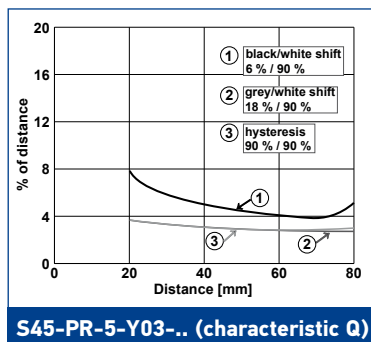

MODEL SELECTION AND ORDER INFORMATION

OPTIC FUNCTION	EMISSION	CONNECTION	OUTPUT	MODEL	ORDER NO.
Diffused proximity	LED	2m Cable	PNP	S45-PR-2-C03-PH	950411220
			NPN	S45-PR-2-C03-NH	950411210
		M8	PNP	S45-PR-5-C03-PH	950411240
			NPN	S45-PR-5-C03-NH	950411230
	LASER	M8	PNP	S45-PH-5-C03-PH	950411260
			NPN	S45-PH-5-C03-NH	950411250
Polarized Retroreflective	LED	2m Cable	PNP	S45-PR-2-B03-PH	950411100
			NPN	S45-PR-2-B03-NH	950411090
		M8	PNP	S45-PR-5-B03-PH	950411120
			NPN	S45-PR-5-B03-NH	950411110
	LASER	M8	PNP	S45-PH-5-B03-PH	950411140
			NPN	S45-PH-5-B03-NH	950411130
Polarized retroreflective autocollimated for transparent	LED	2m Cable	PNP	S45-PR-2-T53-PH	950411160
			NPN	S45-PR-2-T53-NH	950411150
		M8	PNP	S45-PR-5-T53-PH	950411180
			NPN	S45-PR-5-T53-NH	950411170
Polarized retroreflective autocollimated	LED	M8	PNP	S45-PR-5-B53-PH	950411200
			NPN	S45-PR-5-B53-NH	950411190
Through beam	LED	2m Cable	-	S45-PR-2-G00-XE	950411000
			PNP	S45-PR-2-F03-PH	950411020
			NPN	S45-PR-2-F03-NH	950411010
		M8	-	S45-PR-5-G00-XE	950411030
			PNP	S45-PR-5-F03-PH	950411050
			NPN	S45-PR-5-F03-NH	950411040
	LASER	M8	-	S45-PH-5-G00-XE	950411060
			PNP	S45-PH-5-F03-PH	950411080
			NPN	S45-PH-5-F03-NH	950411070
			PNP	S45-PR-2-M03-PH	950411280
Background suppressor 200mm	LED	2m Cable	NPN	S45-PR-2-M03-NH	950411270
			PNP	S45-PR-5-M03-PH	950411300
		M8	NPN	S45-PR-5-M03-NH	950411290
Background suppressor 400mm	LED	2m Cable	PNP	S45-PR-2-M13-PH	950411320
			NPN	S45-PR-2-M13-NH	950411310
		M8	PNP	S45-PR-5-M13-PH	950411340
			NPN	S45-PR-5-M13-NH	950411330
Background suppressor laser	LASER	M8	PNP	S45-PH-5-M03-PH	950411360
			NPN	S45-PH-5-M03-NH	950411350
Distance sensor	LED	M8	PNP	S45-PR-5-Y03-PV	950411380
			NPN	S45-PR-5-Y03-NV	950411370
Distance sensor	LED	M8	PNP	S45-PR-5-Y13-PV	950411400
			NPN	S45-PR-5-Y13-NV	950411390
Contrast Sensor 10kHz	WHITE	M8	PUSH-PULL	S45-PR-5-W03-OH	950411420
	RGB		PUSH-PULL	S45-PR-5-W13-OH	950411410
Contrast Sensor 25kHz	WHITE	M8	PUSH-PULL	S45-PR-5-W33-OH	950411440
	RGB		PUSH-PULL	S45-PR-5-W43-OH	950411430

ACCESSORIES

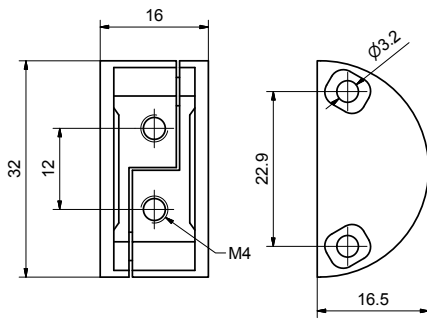

ST-S45-DVT

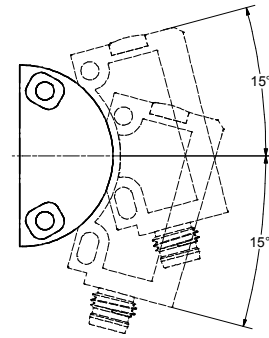

ST-S45-DVT

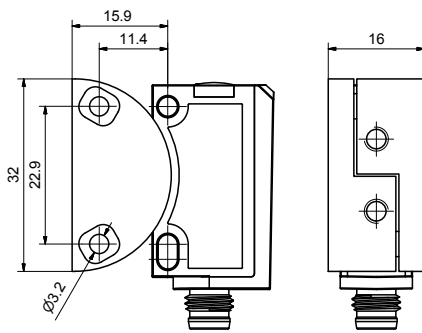

ST-S45-DVT

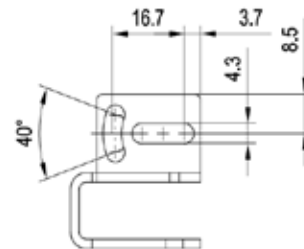
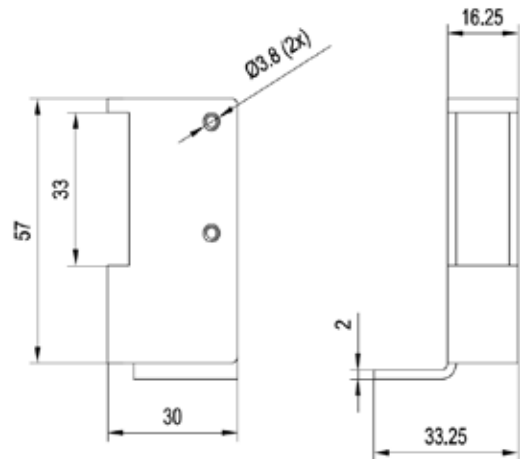

ST-MINI-PRO

MODEL	DESCRIPTION	ORDER NO.
ST-S45-DVT	S45 DOVE TAIL BRACKET	95ACC7970
ST-MINI-PRO	MINI PROTECTIVE BRACKET	95ACC7980

CABLES

TYPE	DESCRIPTION	LENGTH	MODEL	ORDER No.
Axial M8 Connector	4-pole, grey, P.V.C.	3 m	CS-B1-02-G-03	95A251420
		5 m	CS-B1-02-G-05	95A251430
		7 m	CS-B1-02-G-07	95A251440
		10 m	CS-B1-02-G-10	95A251480
	4-pole, P.U.R.	2 m	CS-B1-02-R-02	95A251620
		5 m	CS-B1-02-R-05	95A251640
Radial M8 Connector	4-pole, grey, P.V.C.	3 m	CS-B2-02-G-03	95A251450
		5 m	CS-B2-02-G-05	95A251460
		7 m	CS-B2-02-G-07	95A251470
		10 m	CS-B2-02-G-10	95A251530
	4-pole, P.U.R.	2 m	CS-B2-02-R-02	95A251630
		5 m	CS-B2-02-R-05	95A251650

Rev. 01, 07/2016

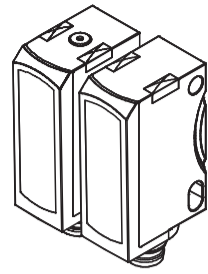

S45-...-G00 S45-...-F03

Emettitore / Ricevitore
Through-beam photoelectric sensor
Barrière optique simple E/R
Einweg-Lichtschranke



821003870 Rev.02 X1610
www.datalogic.com

DATI TECNICI | TECHNICAL DATA | DONNÉES TECHNIQUES | TECHNISCHE DATEN (TYP.)

Emettitore Emitter Émetteur Sender S45				S45-PR-2-G00-XE S45-PR-5-G00-XE	S45-PR-2-F03-PH ^{A)} S45-PR-5-F03-PH ^{A)}	S45-PR-2-F03-NH ^{A)} S45-PR-5-F03-NH ^{A)}	S45-PH-5-G00-XE	S45-PH-5-F03-PH ^{A)}	S45-PH-5-F03-NH ^{A)}	
Ricevitore Receiver Récepteur Empfänger S45	① Uscita di commutazione Q	② Switching output Q	③ Sortie de commutation Q	④ Schaltausgang Q		PNP	NPN		PNP	NPN
Distanza Operativa (RW)	Scanning range (RW)	Portée (RW)	Reichweite (RW)	0 ... 13 m	0 ... 18 m					
Tipo di emissione	Used light	Type de lumière	Lichtart	632 nm, LED rosso red rouge rot	⚠ Laser Classe 1 (IEC 60825-1)					
Dimensione dello spot	Size of light spot	Taille du spot de détection	Lichtfleckgröße	vedere grafici sul retro see back voir verso s. Rückseite						
Tensione di alimentazione +V ³⁾	Operating voltage +V ³⁾	Tension d'alimentation +V ³⁾	Betriebsspannung +V ³⁾	10 ... 30 V DC						
Corrente di assorbimento I ₀	No-load supply current I ₀	Courant hors charge I ₀	Leerlaufstrom I ₀	≤ 30 mA						
Corrente di uscita I _Q	Output current I _Q	Courant de sortie I _Q	Ausgangsstrom I _Q	≤ 100 mA						
Ingresso di TEST (Emettitore)	Controller input TEST (Emitter)	Entrée de commande TEST (Émetteur)	Steuereingang TEST (Sender)	+V = off -V / non connesso = funzionamento normale				+V = off -V / non connesso = funzionamento normale		
Ingresso di TEST (Ricevitore) ⁴⁾	Control input IN (Receiver) ⁴⁾	Entrée de contrôle IN (Récepteur) ⁴⁾	Steuereingang IN (Empfänger) ⁴⁾	+V = Teach-in -V = non connesso = funzionamento normale					+V = Teach in / -V = non connesso = funzionamento normale	
Frequenza operativa (ti/tp 1:1)	Switching frequency (ti/tp 1:1)	Fréquence de commutation (ti/tp 1:1)	Schaltfrequenz (ti/tp 1:1)	≤ 1000 Hz					≤ 2000 Hz	
Grado di protezione ⁵⁾	Enclosure rating ⁵⁾	Degré de protection ⁵⁾	Schutzart ⁵⁾	IP 67 / IP 69K						
Temperatura di funzionamento ²⁾	Ambient air temperature: operation ²⁾	Température ambiante: fonctionnement ²⁾	Umgebungstemperatur: Betrieb ²⁾	-20 ... +60 °C						
Temperatura di immagazzinamento	Ambient air temperature: storage	Température ambiante: stockage	Umgebungstemperatur: Lager	-20 ... +80 °C						
Peso con connettore / con cavo	Weight plug-/ cable device	Poids Capteur avec connecteur-/câble	Gewicht Stecker-/ Kabelgerät	10 g / 40 g						
Configurazione di fabbrica	Factory setting	Configuration d'origine	Werkseinstellung	max. RW, N.O.						

¹⁾ Ⓚ excepto i tipi: S45-PR-5/-PH-5-F03... S45-PR-5/-PH-5-G00-XE
²⁾ UL: -20 ... +50 °C
³⁾ massima variazione residua del 10% della tensione di alimentazione, ~50Hz/100Hz
⁴⁾ vedere il grafico H; sul retro
⁵⁾ con connettore inserito IP 67 / IP 69K

¹⁾ Ⓜ except for types S45-PR-5/-PH-5-F03... S45-PR-5/-PH-5-G00-XE
²⁾ UL: -20 ... +50 °C
³⁾ max. residual ripple 10%, within U_B, approx. 50Hz/100Hz
⁴⁾ see illustration H; back
⁵⁾ with connected IP 67 / IP 69K plug

¹⁾ Ⓛ sauf les types S45-PR-5/-PH-5-F03... S45-PR-5/-PH-5-G00-XE
²⁾ UL: -20 ... +50 °C
³⁾ Ondulation résiduelle maxi 10 % à l'intérieur de U_B, env. 50Hz/100Hz
⁴⁾ voir illustration H; verso
⁵⁾ avec connecteur IP 67 / IP 69K raccordé

¹⁾ Ⓞ ausgenommen Typen S45-PR-5/-PH-5-F03... S45-PR-5/-PH-5-G00-XE
²⁾ UL: -20 ... +50 °C
³⁾ max. 10% Restwelligkeit, innerhalb U_B, ~50Hz/100Hz
⁴⁾ siehe Grafik H; Rückseite
⁵⁾ mit angeschlossenem IP 67 / IP 69K Stecker

^{A)} Ⓛ Teach-in ^{A)} Ⓜ Teach-in ^{A)} Ⓛ Teach-in ^{A)} Ⓛ Teach-in

= Tasto bloccato = button locked = bouton verrouillée = Taste verriegelt

INDICAZIONI SDI SICUREZZA

Leggere attentamente le istruzioni prima della messa in servizio del sensore.
Connessione, Montaggio e messa in servizio devono essere eseguite da personale qualificato.
No es una pieza de seguridad según la directiva de máquinas de la UE (no es adecuada para la protección de personas).
Non utilizzare in ambiente esterno.
S45-PH-5-G00-XE: ⚠, classe 1; lunghezza d'onda: 650nm; frequenza: 13,3kHz; ampiezza dell'impulso: 1,4µs; valore limite dell'impulso: 4,2mW (IEC 60825-1).
Conforme alla norma 21 CFR 1040.10 y 1040.11, eccetto le differenze conformi alla nota del laser n. 50 del 24 Giugno 2007.
Per l'uso dei sensori con connettore: Connettore M8 metallico dritto o 90° Zoccolo di connessione R/C (CYJV2).
ATTENZIONE - tutto ciò che riguarda l'utilizzo nel controllo o regolazione eseguito diversamente da quanto descritto in questo manuale può provocare una esposizione pericolosa alla radiazione del laser.
BUSO CORRETTO
I sensori sono usati per rilevare oggetti senza contatto.
MONTAGGIO
Montare Emittitore e Ricevitore uno di fronte all'altro correttamente allineati usando i relativi accessori (vedere il sito www.datalogic.com).

SAFETY INSTRUCTIONS

Read operating instructions before start-up.
Connection, assembly, setting and start-up only by trained personnel.
No safety component according to EU machinery directives (not suited for the protection of personnel).
Not for outdoor use.
S45-PH-5-G00-XE: ⚠, class 1; wavelength: 650nm; frequency: 13.3kHz; pulse duration: 1.4µs; limit value pulse: 4,2mW (IEC 60825-1).
Complies with 21 CFR 1040.10 and 1040.11 except for deviations pursuant to laser Notice No. 50 dated June 24, 2007
For use with sensors with connector: Straight or L-shaped M8 metal connector, connector base is made of R/C (CYJV2).
CAUTION - Use of Controls or adjustments or performance of procedures other than those specified herein may result in hazardous radiation exposure.
INTENDED USE
Sensors are used for the optical non-contact detection of objects.
ASSEMBLY
Mount the emitter and the receiver adjacent to each other (bracket see www.datalogic.com).

INSTRUCTIONS DE SÉCURITÉ

Lire les instructions de service avant mise en service.
Raccordement, assemblage, réglage et mise en service ne doivent être effectués que par du personnel qualifié.
Il ne s'agit pas de pièces de sécurité selon les directives européennes en vigueur concernant les machines (inappropriées à la protection de personnes).
Nepas utiliser à l'extérieur.
S45-PH-5-G00-XE : ⚠, classe 1 ; longueur d'onde : 650nm ; fréquence : 13,3kHz ; longueur d'impulsion : 1,4µs ; valeur limite impulsion : 4,2mW (IEC 60825-1).
Correspond à 21 CFR 1040.10 et 1040.11 à l'exception des différences conformément à la notice du laser n° 50 du 24 juin 2007
Pour une utilisation avec capteurs avec connecteur : Connecteur métallique M8 droit ou en forme de " L ", socle de raccordement en R/C (CYJV2).
ATTENTION - L'utilisation de commandes, de réglages ou de consignes autres que ceux spécifiés présente un risque d'exposition dangereuse aux radiations.
UTILISATION CONFORME
Les capteurs sont utilisés pour la détection optique des objets sans contact.
MONTAGE
Monter l'émetteur en face du récepteur (support voir www.datalogic.com).

SICHERHEITSHINWEISE

Vor Inbetriebnahme die Betriebsanleitung lesen.
Anschluss, Montage, Einstellung und Inbetriebnahme nur durch Fachpersonal.
Kein Sicherheitsbauteil gemäß EU-Maschinenrichtlinie (nicht zum Schutz von Personen geeignet).
Einsatz nicht im Aussenbereich.
S45-PH-5-G00-XE: ⚠, Klasse 1; Wellenlänge: 650nm; Frequenz: 13,3kHz; Pulsbreite: 1,4µs; Grenzwert Puls: 4,2mW (IEC 60825-1).
Entspricht 21 CFR 1040.10 und 1040.11 mit Ausnahme der Abweichungen gemäß Laser Notiz Nr. 50 vom 24. Juni 2007
Zur Verwendung mit Sensoren mit Stecker: Gerader oder L-förmiger M8 Metallstecker, Anschlusssockel aus R/C (CYJV2).
ACHTUNG - Durch Verwendung von Bedienelementen oder Einstellungen sowie Durchführung von Verfahren, die nicht hier angegeben sind, kann es zum Austritt gefährlicher Strahlung kommen.
BESTIMMUNGSGEMÄSSE VERWENDUNG
Sensoren werden zum optischen berührungslosen Erfassen von Objekten eingesetzt.
MONTAGE
Sender und Empfänger gegenüberliegend montieren (Halter s. www.datalogic.com).

A. DIMENSIONI DI INGOMBRO | DIMENSIONAL DRAWING | PLAN COTES | MASSBILD

①	②	③	④
1 LED Giallo ¹⁾	Yellow LED ¹⁾	LED jaune ¹⁾	LED gelb ¹⁾
2 Tasto ²⁾	Button ²⁾	Bouton ²⁾	Taste ²⁾
3 LED Verde ³⁾	Green LED ³⁾	LED verte ³⁾	LED grün ³⁾
4 Asse di ricezione	Receiver axis	Axe de récepteur	Empfängerachse
5 Asse di emissione	Emitter axis	Axe d'émetteur	Senderachse

1) Ricevitore: Indicatore dello stato di uscita | Receiver: Switching output indicator | Récepteur: Afficheur sortie de commutation | Empfänger: Schaltausgangsanzeige
2) non utilizzato nel Trasmettitore | not applicable for emitter | n'est pas pertinent pour émetteur | entfällt für Sender
3) Indicatore della tensione di alimentazione attiva | operating voltage indicator afficheur tension de service | Betriebsspannungsanzeige

	S45-PR-x-G00	S45-PH-5-G00
A	11,5	13,5
B	22,3	

B. CONNESSIONE | CONNECTION | RACCORDEMENT | ANSCHLUSS

S45	-	PR	-	2	-	G00	-	XE	Example
S45	-	PR	-	2	-	F03	-	PH	Example

S45	-	xx	-	2	-	xxx	-	PH	4-pin
S45	-	xx	-	2	-	xxx	-	NH	
S45	-	xx	-	5	-	xxx	-	PH	
S45	-	xx	-	5	-	xxx	-	NH	

2 is not available for S45-PH-...

C. MODALITA' DI COMMUTAZIONE | SWITCHING MODE | TYPE DE COMMUTATION | SCHALTART

PNP		LED giallo
N.O.	+V	
N.C.	-V	
N.O.	+V	
N.C.	-V	

NPN		LED giallo
N.C.	+V	
N.O.	-V	
N.C.	+V	
N.O.	-V	

D. POSIZIONAMENTO | ADJUSTMENT | AJUSTEMENT | JUSTAGE

Emettitore Ricevitore

CONNESSIONE
 Inserire il connettore senza alimentazione ed avvertirlo fino in fondo.
 Connettere il cavo come in figura B.
 Vedere figura C per connessione PNP/NPN.
 Tensione presente → LED Verde acceso.
 Logica di uscita N.O. ↔ N.C. (vedi figura G).
 N.O. Normalmente Aperto; N.C. Normalmente Chiuso.

POSIZIONAMENTO (VEDI FIGURA D)
 Allineare correttamente Emittitore e Ricevitore fino a quando il LED giallo sul ricevitore non si spegne.
 TEST: Collegare l'input di TEST dell'emittitore a +V. L'emittitore si spegnerà, il ricevitore commuterà l'uscita ed il LED giallo del ricevitore cambierà di stato. Se il Ricevitore non commuta l'uscita, ripetere correttamente la regolazione e verificare il funzionamento del sistema.

CONFIGURAZIONE
 Il Sensore ha due differenti metodi di regolazione con TEACH-IN.
Regolazione Standard (STI): utilizzata nella maggior parte delle applicazioni, si esegue acquisendo prima l'emittitore correttamente allineato poi l'oggetto (vedere figura E).
Regolazione Dinamica (DTI): utilizzata per rilevare l'oggetto durante il funzionamento della macchina ed in particolare per oggetti piccoli (vedi figura F).

MANUTENZIONE
 Il sensore è libero da manutenzione.

CONNECTION
 Insert plug tension-free and screw it tightly.
 Connect cable according to the connection diagram (see illustration B).
 For PNP/NPN (see illustration C).
 Apply voltage → green LED lights up.
 Switching N.O. ↔ N.C. (see illustration G).
 N.O. = normally open; N.C. = normally closed.

ADJUSTMENT (SEE ILLUSTRATION D)
 Align the emitter and the receiver to each other until the yellow LED (receiver) switches off.
 TEST: Switch the test input emitter to +V. The emitter will switch off, the receiver will perform a switching and the yellow LED (receiver) will change its state. If the receiver does not execute any switching repeat the adjustment and check the system settings.

SETTING
 The sensor has 2 different Teach-in modes.
Standard Teach-in (STI): is suited for nearly all applications. The setting is performed targeted towards the receiver and the object (see illustration E).
Dynamic Teach-in (DTI): is suited for setting the sensor in the running process, particularly for small objects (see illustration F).

MAINTENANCE
 Sensors are maintenance-free. We recommend to cyclically clean the optical surfaces and check the screw connections and plug connections.

RACCORDEMENT
 Enficher le connecteur sans tension et le visser.
 Connecter le câble selon le schéma de raccordement (voir illustration B).
 Pour PNP/NPN (voir illustration C).
 Mettre sous tension → LED verte est allumée.
 Inversion N.O. ↔ N.C. (voir illustration G).
 N.O. = ouverture ; N.C. = fermeture.

AJUSTEMENT (VOIR ILLUSTRATION D)
 Aligner l'émetteur sur le récepteur jusqu'à ce que la LED (récepteur) jaune s'éteigne.
 TEST : connecter l'entrée test émetteur sur +V. L'émetteur s'éteint, le récepteur commute et la LED jaune (récepteur) change d'état. Si le récepteur ne commute pas, répéter l'ajustage et contrôler les réglages du système.

RÉGLAGE
 Le capteur a 2 modes différents d'apprentissage (Teach-in).
Standard Teach-in (STI) : est adapté à presque toutes les applications. Réglage par rapport au récepteur et à l'objet (voir illustration E).
Dynamic Teach-in (DTI) : est approprié pour régler le capteur pendant qu'il est en service, particulièrement pour les petits objets (voir illustration F).

ENTRETIEN
 Les capteurs ne demandent aucun entretien. Nous recommandons de nettoyer les surfaces optiques et vérifier les raccordements et les fixations régulièrement.

ANSCHLUSS
 Stecker spannungsfrei aufstecken und festschrauben.
 Leitung anschliessen. Es gilt das Anschlusschema (s. Grafik B).
 Für PNP/NPN gilt (s. Grafik C).
 Spannung anlegen → LED grün leuchtet.
 Umschaltung N.O. ↔ N.C. (s. Grafik G).
 N.O. = Schließer; N.C. = Öffner.

JUSTAGE (S. GRAFIK D)
 Sender und Empfänger aufeinander ausrichten bis gelbe LED (Empfänger) erlischt.
 TEST: Testeingang Sender an +V legen. Sender erlischt, Empfänger schaltet und gelbe LED (Empfänger) ändert ihren Zustand. Schaltet Empfänger nicht, Justage wiederholen und Systemeinstellungen überprüfen.

EINSTELLUNG
 Der Sensor verfügt über 2 unterschiedliche Teach-in-Modi.
Standard Teach-in (STI): ist für nahezu jede Anwendung geeignet. Einstellung erfolgt auf den Empfänger und das Objekt (s. Grafik E).
Dynamic Teach-in (DTI): ist geeignet den Sensor im laufenden Prozess einzustellen, speziell bei kleinen Objekten (s. Grafik F).

WARTUNG
 Sensoren sind wartungsfrei. Es wird empfohlen in regelmäßigen Intervallen die optischen Flächen zu reinigen und Verschraubungen und Steckverbindungen zu überprüfen.

STANDARD TEACH-IN (STI) | TEACH IN STANDARD

Step 1: Teach-in emitter/receiver / Apprendimento Emittitore con Ricevitore

Step 2: Teach-in object / Apprendimento oggetto

External Teach-in / Teach in Esterno → H.

DYNAMIC TEACH-IN (DTI) | APPRENDIMENTO DINAMICO

Step 1: During running process / Durante il processo avviato

Step 2: Teach-in object during running process / Apprendimento oggetto con processo avviato

External Teach-in / Teach in Esterno → H.

SELEZIONE N.O. / N.C. | SWITCHING N.O. / N.C. | INVERSION N.O. / N.C. | UMSCHALTUNG N.O. / N.C.

premere pulsante ricevitore > 13 s
 until green & yellow LED flash alternately / fino a che il LED verde e giallo lampeggiano alternativamente

→ **N.O.**
 green LED flashes yellow LED OFF / LED verde lampeggia LED giallo OFF

↓ wait 10 s

premere pulsante ricevitore → **N.C.**
 green LED flashes yellow LED ON / LED verde lampeggia LED giallo ON

↓ wait 10 s

premere pulsante ricevitore → **N.O. ...**

EXTERNAL TEACH-IN | TEACH IN ESTERNO

① **Regolazione con TEACH IN esterno:** Comandare l'ingresso con le stesse tempistiche del pulsante di teach in.

② **Setting via control input IN:** Closing and opening times according to the corresponding indications for the button.

③ **Réglage par entrée de contrôle IN :** Temps de fermeture et d'ouverture selon l'indication correspondante de la bouton.

④ **Einstellung über Steuereingang IN:** Schließ- und Öffnungsdauer analog den jeweiligen Angaben für die Taste.

