



Horizontal rotary clamp cylinder——QDK Series

Compendium of QDK Series



Criteria for selection: Cylinder thrust

Unit □ Newton(N)

Bore size	Rod size	Acting type	Operating pressure(MPa)							
			0.1	0.2	0.3	0.4	0.5	0.6	0.7	0.8
20	12	IN(Clamp)	-	20.1	40.2	60.3	80.4	100.5	120.6	140.7
25	12	IN(Clamp)	17.7	55.5	93.3	131.1	168.9	206.7	244.5	282.3
32	12	IN(Clamp)	43.1	111.2	181.3	250.4	319.5	388.6	457.7	526.8
40	16	IN(Clamp)	75.2	180.7	286.2	391.7	497.2	602.7	708.2	813.7

Installation and application



1. Dirty substances in the pipe must be eliminated before cylinder is connected with pipeline to prevent the entrance of impurities into the cylinder.
2. The medium used by cylinder shall be filtered to 40μm or below.
3. Anti-freezing measure shall be adopted under low temperature environment to prevent moisture freezing.
4. If the cylinder is dismantled and stored for a long time, please conduct anti-rust treatment to the surface. Anti-dust jam cap shall be added in air inlet and outlet ports.
5. To insure the life-span of cylinder and jig, please use flow control valve to control the speed of cylinder.



Horizontal rotary clamp cylinder



QDK Series



Specification

Bore size(mm)	20	25	32	40
Acting type	Double acting			
Fluid	Air(to be filtered by 40μm filter element)			
Operating pressure	0.15~1.0MPa(22~145psi)			
Proof pressure	1.5MPa(220psi)			
Temperature	-20~70℃			
Rotation angle	90°			
Repeatability	±2°			
Rotation direction	Turn left or turn right			
Rotation stroke(mm)	0(Horizontal rotary)			
Clamping stroke (mm)	5			
Cushion type	Bumper			
Port size	M5×0.8			1/8"

Add) please refer to Page 451 for the specific content of sensor switch.

Symbol

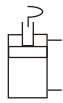

Product feature

1. Complete rotation on horizontal plane, so more save space compare with QCK series.
2. Boss front end cap and flush front end cap are available.
3. Double pins in the rotation guide groove to increase stability.
4. There are magnetic switch slots around the cylinder body convenient to install inducting switch.

Ordering code

QDK L 32 x 5 S U G

① ② ③ ④ ⑤ ⑥ ⑦

① Model	② Rotation direction	③ Bore size	④ Clamping stroke	⑤ Magnet	⑥ Front cover type	⑦ Thread type [Note 1]
QDK: Horizontal rotary clamp cylinder	L: Push and turn left R: Push and turn right	20 25 32 40	5: 5mm	S: With magnet	Blank: Boss front end cap U: Flush front end cap	G: G

[Note 1] When the thread is standard, the code is blank.

The definition of rotation direction and angle

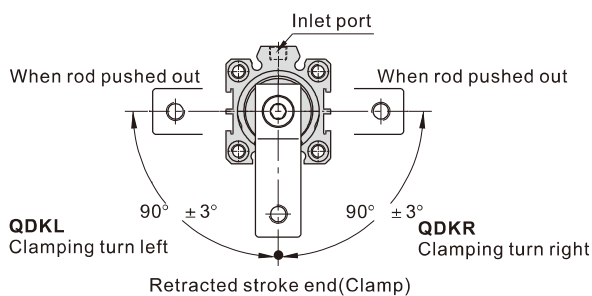

Levorotatory(QDKL):
When the piston of cylinder moves downward, the swivel arms moves anticlockwise, this is call edlevorotatory.

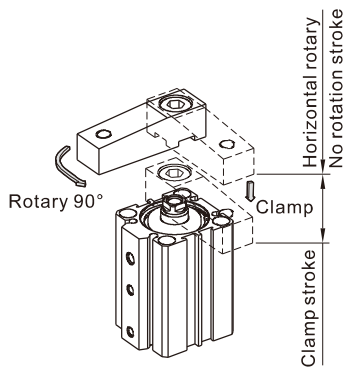

The order code is L

Dextrorotatory(QDKR):
When the piston of cylinder moves downward, the swivel arms moves clockwise. this is called dextrorotatory.

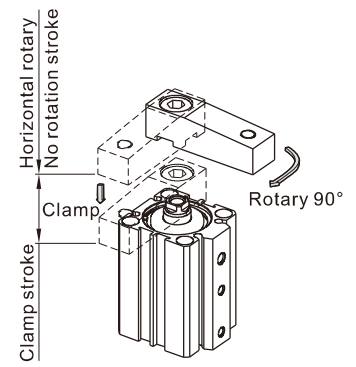

The order code is R



Horizontal rotary clamp cylinder

QDK Series

Inner structure and material of major parts

QDK(Boss front end cap)

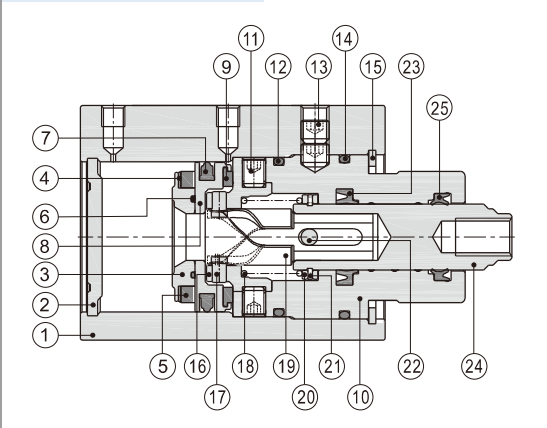

NO.	Item	Material	NO.	Item	Material
1	Body	Aluminum alloy	13	Fixing screw	Carbon steel
2	Back cover	Aluminum alloy	14	O-ring	NBR
3	Magnet holder	Aluminum alloy	15	C clip	Spring steel
4	Magnet washer	NBR	16	Middle seat	SCR440
5	Magnet	Sintered metal (Neodymium-iron-boron)	17	Pin	SUJ2
			18	Spring	Stainless steel
6	O-ring	NBR	19	Rotary axis	SCR440
7	Piston seal	NBR	20	Stop flake	Stainless steel
8	Piston	Aluminum alloy(Φ40)/brass(Other)	21	C clip	Spring steel
9	Bumper	TPU	22	Pin	SUJ2
10	Front cover	Aluminum alloy	23	Front cover parking	NBR
11	Fixing screw	Carbon steel	24	Piston rod	SCR440
12	O-ring	NBR	25	Front cover parking	NBR

Dimensions

QDK(Boss front end cap)

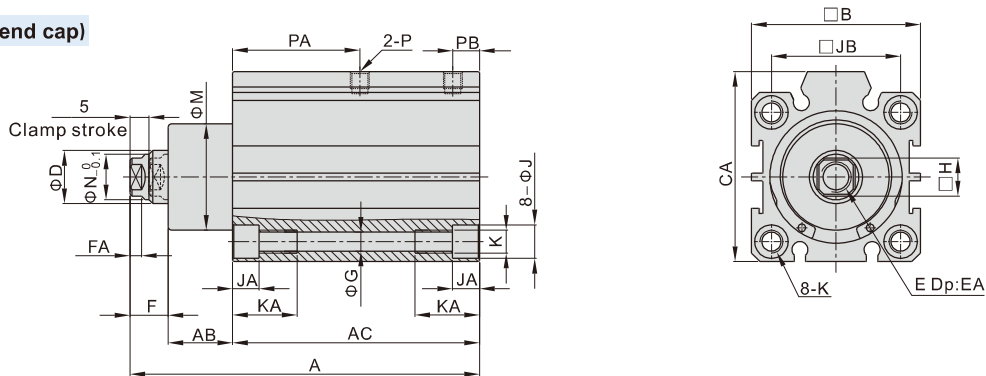

Bore size\Item	A	AB	AC	B	CA	D	E	EA	F	FA	G	H	J	JA	JB	K	KA	M	N	P	PA	PB
20	86.5	16.5	60	34	-	12	M6X1.0	7.5	10	3	4.2	8	7.3	4.5	24	M5X0.8	14	24	10	M5X0.8	31.5	7
25	86.5	16.5	60	40	-	12	M8X1.25	8	10	3	5.2	10	9	5.5	28	M6X1.0	17	26	-	M5X0.8	31	7
32	92	17	65	44.5	50	14	M8X1.25	10	10	3	5.2	10	9	5.5	34	M6X1.0	17	28	12	M5X0.8	33.5	7
40	98	18	70	52	58.5	16	M8X1.25	10	10	3	6.8	14	10.5	6.5	40	M8X1.25	20	30	-	1/8"	35	9

QDK-U(Flush front end cap)

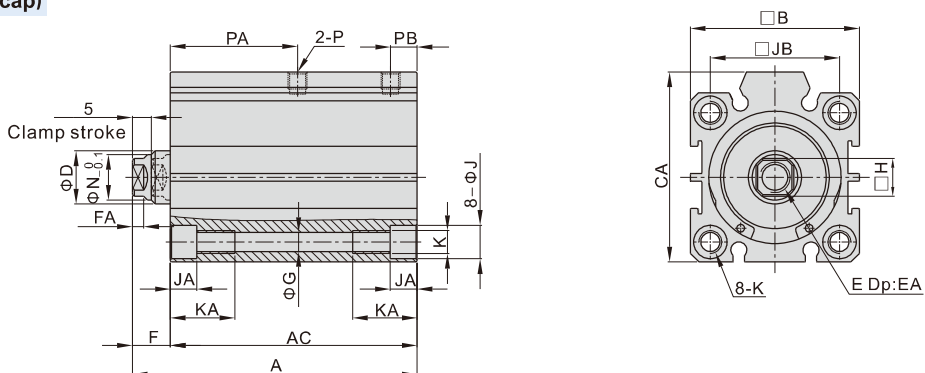

Bore size\Item	A	AC	B	CA	D	E	EA	F	FA	G	H	J	JA	JB	K	KA	N	P	PA	PB
20	70	60	34	-	12	M6X1.0	7.5	10	3	4.2	8	7.3	4.5	24	M5X0.8	14	10	M5X0.8	31.5	7
25	70	60	40	-	12	M8X1.25	8	10	3	5.2	10	9	5.5	28	M6X1.0	17	-	M5X0.8	31	7
32	75	65	44.5	50	14	M8X1.25	10	10	3	5.2	10	9	5.5	34	M6X1.0	17	12	M5X0.8	33.5	7
40	80	70	52	58.5	16	M8X1.25	10	10	3	6.8	14	10.5	6.5	40	M8X1.25	20	-	1/8"	35	9