

Foot switches



Foot switches PS... / PD

Double insulation - Plastic Casing IP65 - Description

APPLICATIONS

Foot switch operated machines such as: shearing machines, spinning machines, spinning lathers, machine tools, wrapping machines, riveting presses, etc.
Foot switches come in five operation formats:

- **Free movement:** contact position follows pedal movement: actuated when the pedal is pushed down, released when pedal is in state of rest.
- **Foot switch locked in neutral position:** same operation as above, after unlocking the pedal with the end of the foot.
- **Foot switch latched in low position:** same operation as free movement, excepted that a state of rest is obtained only after having unlatched the pedal with the end of the foot.
- **Free movement with two-stage actuating force:** two different contact blocks are actuated with a different force on the lever.
- **Foot switch locked in neutral position with two-stage actuating force:** same operation as above, after unlocking the pedal with the end of the foot

DESCRIPTION OF THE SWITCH

- **Dimensions:** 280 x 140 x 138mm.
- **Materials:** **Standard version (IMQ approved):** Base, cover and pedal made of shock resistant ABS material.
Self-extinguishing / VO (IMQ, UL, CSA approved): Base, cover and pedal made of Polycarbonate/ABS-V0.
Metal version / VO-M (IMQ, UL, CSA approved): Cover made in die cast aluminium, base and pedal made of Polycarbonate/ABS-V0.
- **Colour choice:** Grey base; grey, yellow or red cover.
- **Variations:** Grey base, half-red cover. Especially used for emergency stop function.

They comply with the requirements of European Directives (Low Voltage and RoHS) and are conform to European and International Standards.

The CE declaration of these products are available in the download section of website www.comepi.it or by writing to the following email address: tecnico@comepi.it
DDC05 - Foot Switches.

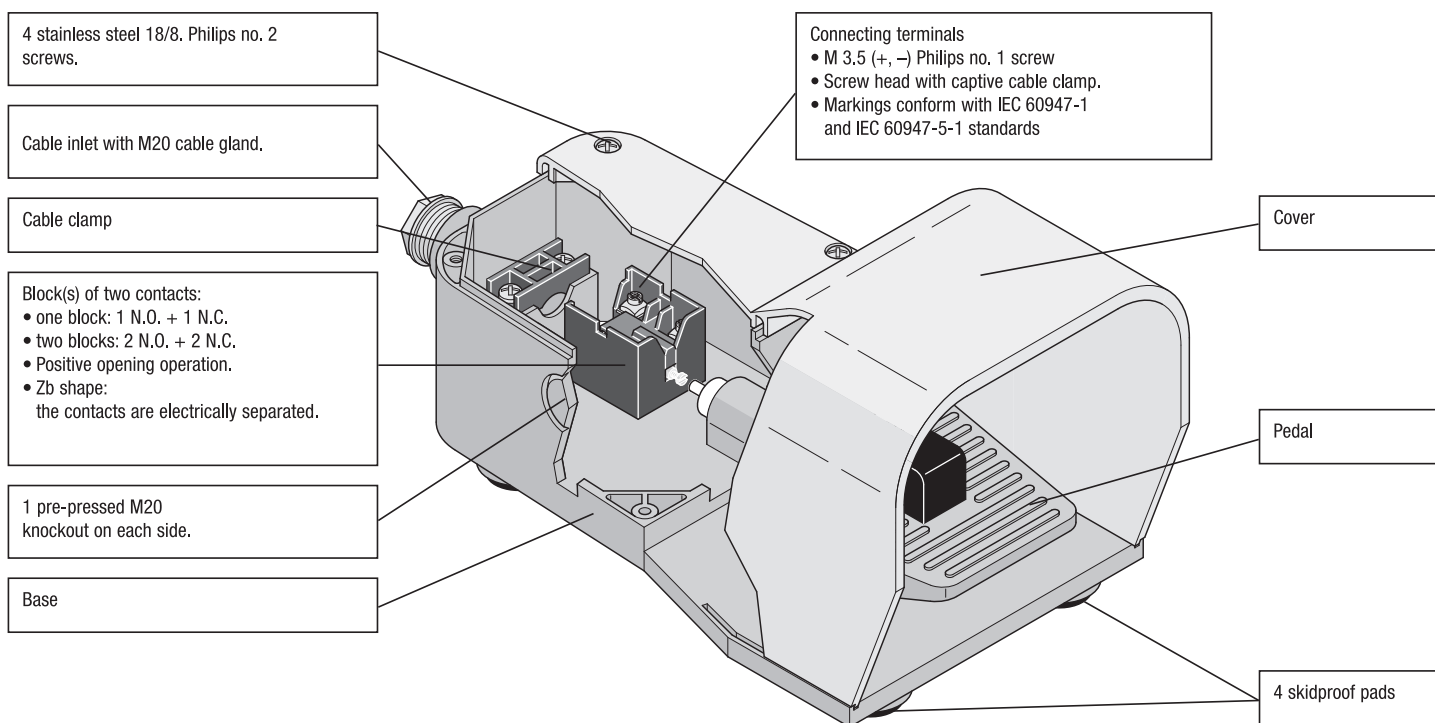

Dimensions (in mm)

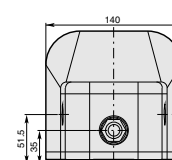
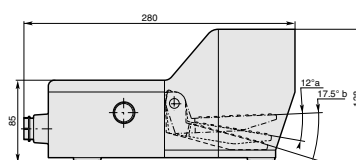

Foot switches PS... / PD

Double insulation - Plastic Casing IP65 - Description

Symbols

Example:

P	S	1	2	1	1
---	---	---	---	---	---

 /

VO

Structure:

P					
---	--	--	--	--	--

 /

--

Type
S = Simple Foot Switch
D = Double Foot Switch

Electrical connection
1 = Pg 16 cable gland
2 = M20 cable gland

Devices
1 = Free movement of the lever
2 = Movement of the lever dependent of the safety device notch
3 = Device to maintain the lever in lowered down position
4 = Free movement with two-stage actuating force
5 = With safety device notch and two-stage actuating force

Contact blocks
1 - One (NO+NC) snap action contact
2 - One (NO+NC) slow action contact
3 - Two (NO+NC) snap action contacts
4 - Two (NO+NC) slow action contacts

Cover material
- = Shock resistant ABS (standard)
VO = UL approved self-extinguishing
VO-M = UL approved with aluminium cover

Cover colour 1 = Yellow / 2 = Grey / 3 = Yellow + Grey (PD series)
4 = Red / 5 = Half red cover / 7 = Half yellow cover / 8 = Half grey cover

DEVICES

1: Free movement of the lever

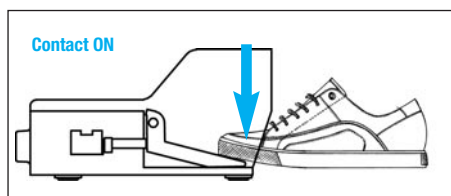
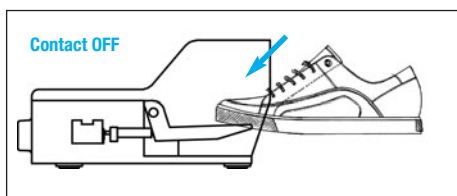

The lever can be actuated without any particular device.

2: Movement of the lever dependent of the safety device notch

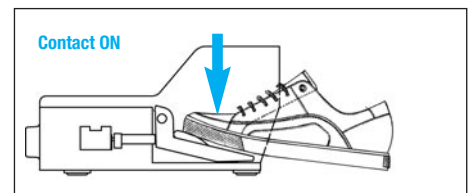
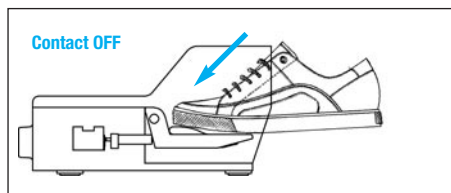
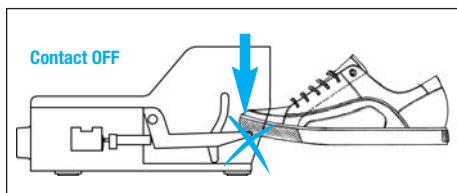

The pedal can be actuated only by lowering the safety lever fully inserting the foot, thus preventing any accidental actuation.

3: Device to maintain the lever in lowered position

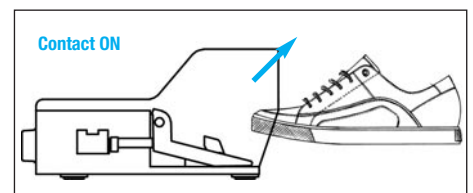
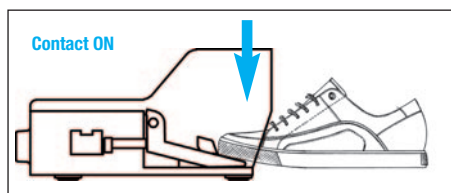
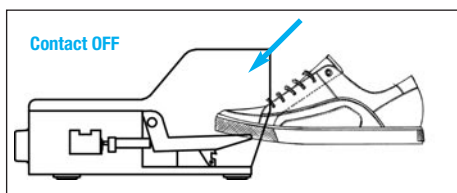

By pushing the lever the contact switches and the lever remains locked in lowered position.

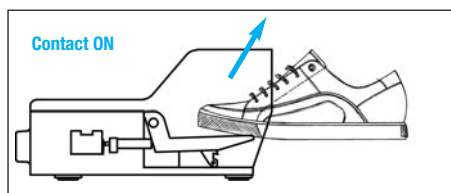
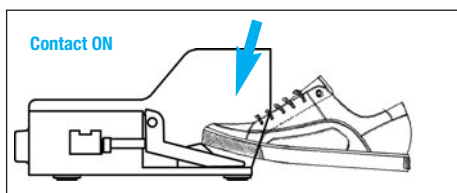

Push the locking device in order to unlock the pedal actuator.
Once you release the lever the contacts return to their initial position.

4: Free movement with two-stage actuating force

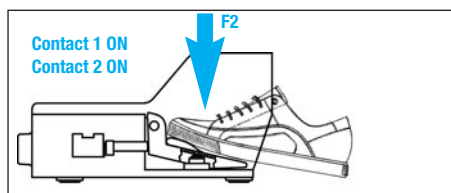
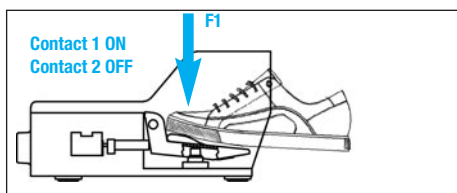

By applying a light pressure F1 on the lever, the first contact block will be actuated while the second keeps in state.
An higher pressure F2 on the lever will switch also the second contact block.

5: With safety device notch and two-stage actuating force

Same as above but the pedal can be actuated only by completely inserting the foot in the device.

Foot switches PS... / PD

Double insulation - Plastic Casing IP65 - Accessories

Carrying Rod Kits

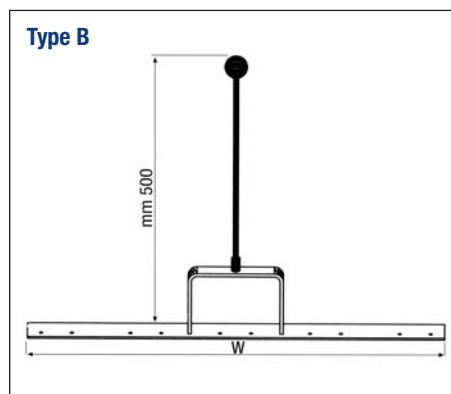
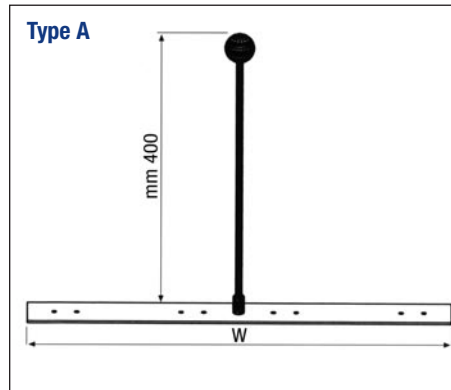
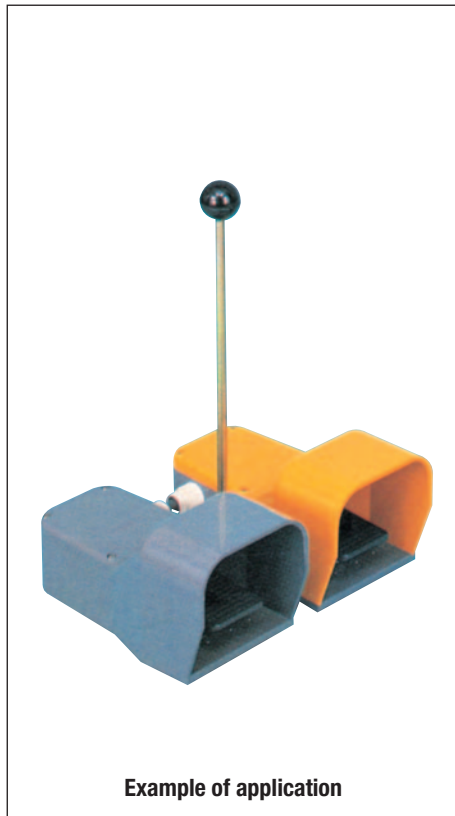

Order Code	Description	W (mm)	Type
PD1000	Max 2 Foot Switches*	225	A
PD1001	Max 3 Foot Switches*	405	B
PD1002	Max 4 Foot Switches*	580	A
PD1003	Max 5 Foot Switches*	745	B

* Foot Switches not included

Note: Each carrying rod kit includes necessary fixing screws and cable glands for the specified number of foot switches.

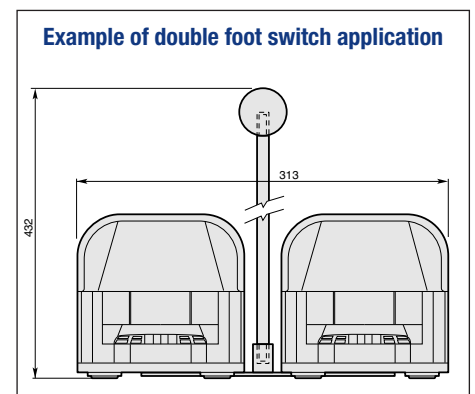

Metal Steel Frame

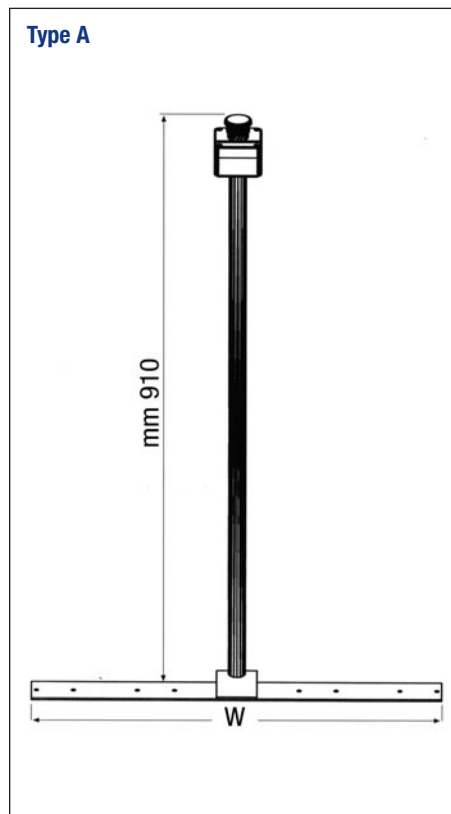

Order Code	Description	W (mm)
GR2025	For 1 foot switch only*	175
GR2026	Max 2 foot switches*	280
GR2027	Max 3 foot switches*	440
GR2028	Max 4 foot switches*	580

* Foot Switches not included

Attention!
Push button and plastic box not included:
please consult our "Control Units 022"
catalog.

Note: Each carrying rod kit includes necessary fixing screws and cable glands for the specified number of foot switches.

Foot switches **PS... / PD**

Two hand control station with support base



GR2030

Aluminium two hand control station

GR2031

Aluminium two hand control station suitable for adjustable support base

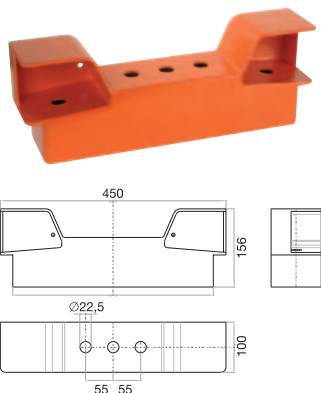

AN003PE

Protection ring

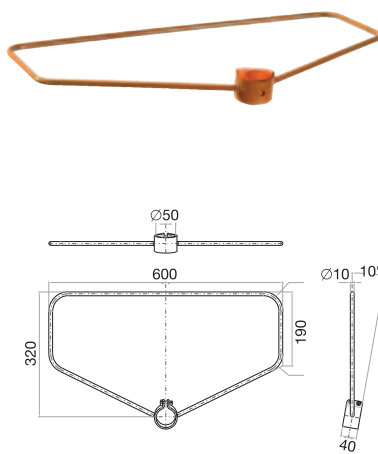

GR2029

Adjustable support base

