

19012318A00

MD38IO1 I/O Expansion Card

User Guide

Suzhou Inovance Technology Co., Ltd.

Add.: No.52, Tian'e Dang Road, Wuzhong District,
Suzhou 215104, P.R. China

Tel: (0512) 6637 6666 Fax: (0512) 6285 6720

www.inovance.com



Preface

■ Introduction

The MD38IO1 card is a multi-function I/O expansion card. It can expand your AC drive with five DI terminals, one AI terminal, one DO terminal, one AO terminal, and one relay output terminal.

The MD38IO1 card also provides the CAN and RS485 communication interfaces for fieldbus control.

This user guide describes the applicable AC drives, dimensions, interfaces, installation, and wiring of this product.

■ Revision History

Date	Version	Description
November 2023	A00	First release

■ Access to the Guide

This guide is not delivered with the product. You can obtain the PDF version in the following ways:

- Visit www.inovance.com, go to "Support" > "Download", search by keyword, and then download the PDF file.
- Scan the QR code on the product with your smart phone.
- Scan the QR code below to install the Inovance app, and search for the following AC drives in the app to obtain this guide.
 - MD290 (T4 and larger models)
 - MD480 (T2 and larger models)
 - MD480-PLUS (T4 and larger models)
 - MD500 (T4 and larger models)
 - MD500E (T4 and larger models)
 - MD500-PLUS (T4 and larger models)
 - MD510 (T4 and larger models)
 - MD520 (T4 and larger models)



■ Warranty

For faults and damage incurred during normal use in the warranty period, Inovance provides free repair service. (For details of the warranty period, see the purchase order.) A maintenance fee will be charged out of the warranty period.

Even in the warranty period, a maintenance fee will be charged for repair of the following damage:

- Damage caused by operations not following the instructions in the guide
- Damage caused by fire, flood, or abnormal voltage
- Damage caused by unintended use of the product
- Damage caused by use beyond the specified scope of application of the product
- Damage or secondary damage caused by force majeure (natural disaster, earthquake, and lightning strike)

The maintenance fee will be charged according to our latest Price List if not otherwise agreed upon.

For details, see the Product Warranty Card.

Table of Contents

Preface.....	1
1 Product Information	4
1.1 Introduction	4
1.2 Applicable AC Drives	5
1.3 Outline Dimensions.....	6
1.4 Interface Description.....	6
2 Installation and Wiring	15
2.1 Installation.....	15
2.2 Wiring	16

1 Product Information

1.1 Introduction

The MD38IO1 card is a multi-function I/O expansion card. It can expand your AC drive with five DI terminals, one AI terminal, one DO terminal, one AO terminal, and one relay output terminal. The MD38IO1 card also provides the CAN and RS485 communication interfaces for fieldbus control.



Figure 1-1 MD38IO1 card appearance

1.2 Applicable AC Drives

Card Model	Order No.	Applicable AC Drive
MD38IO1	01013098	MD290 (T4 and larger models) MD480 (T2 and larger models) MD480-PLUS (T4 and larger models) MD500 (T4 and larger models) MD500E (T4 and larger models) MD500-PLUS (T4 and larger models) MD510 (T4 and larger models) MD520 (T4 and larger models) CS200 (T4 and larger models) CS290 (T4 and larger models) CS710 (T4 and larger models)

1.3 Outline Dimensions

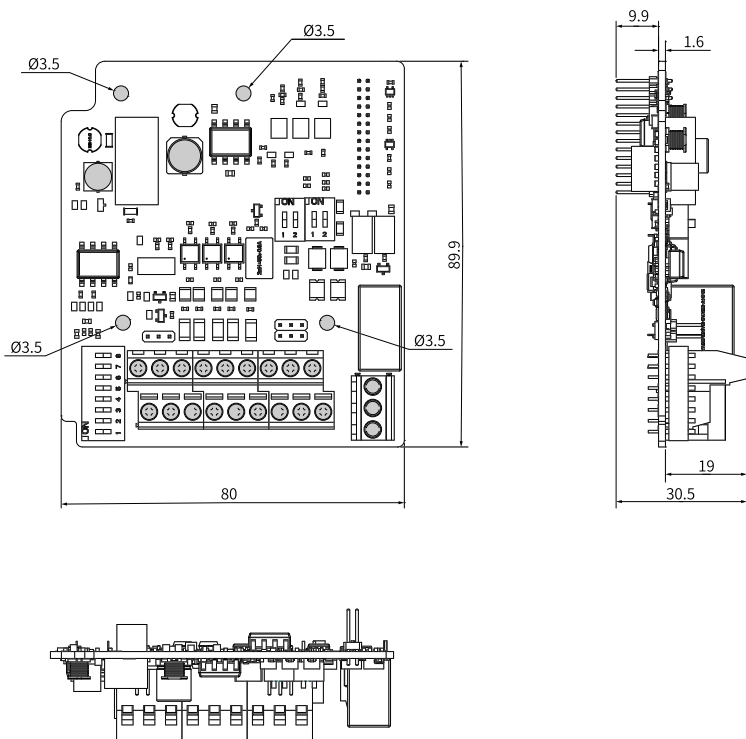

Figure 1-2 MD38IO1 card dimensions (unit: mm)

1.4 Interface Description

■ Interface layout

The MD38IO1 card is a multi-function I/O expansion card designed for the MD500 series AC drives. It can expand your AC drive with five DI terminals, one AI terminal, one DO terminal, one AO terminal, and one relay output terminal. The MD38IO1 card also provides the CAN and RS485 communication interfaces for fieldbus control.

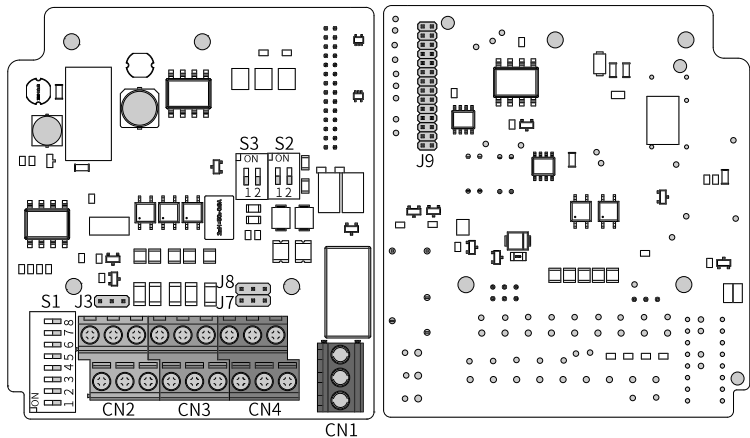
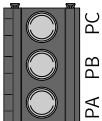
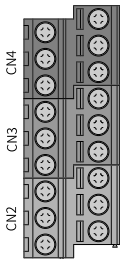

Figure 1-3 MD38IO1 card interface layout

■ Interfaces

Table 1-1 MD38IO1 card interface function description

Mark		Terminal Name	Function Description	Terminal Arrangement
CN1	PA-PB	Normally-closed terminal	Driving capacity of the contact: 250 VAC, 3 A, $\cos\phi = 0.4$ PA-PC normally-open terminal: 30 VDC, 1 A	
	PA-PC	Normally-open terminal		

Mark		Terminal Name	Function Description	Terminal Arrangement
CN2	AI3-PGND	Analog input terminal 3	Photocoupler isolation input, supporting differential voltage input and temperature detection resistance input Input voltage range: -10 VDC to +10 VDC PT100 and PT1000 temperature sensor input The input mode is set by the DIP switch S1. Only one mode can be enabled at a time.	 <p>AI3 AO2 DI6 DI7 DI8 DI9 DI10 C485+ C485- PGND GND DO2 CME +24V OPI COM/CGND CANH CANL</p>
	AO2-GND	AO2	Output voltage: 0 V to 10 V Output current: 0 mA to 20 mA Output current impedance: 0 Ω to 500 Ω	
	DI6	Digital input	Photocoupler isolation, compatible with dual-polarity inputs Input impedance: 2.4 kΩ Voltage upon level input: 9 V to 30 V	
	DO2-CME	Digital output 2	Photocoupler isolation, dual-polarity open-collector output Output voltage range: 0 V to 24 V Output current range: 0 mA to 50 mA Note: The digital output ground terminal CME1 and the digital input ground terminal COM/CGND are internally isolated. They are connected by jumper J7 internally. Remove J7 if you need to power DO2 with an external power supply.	

Mark		Terminal Name	Function Description	Terminal Arrangement
CN3	DI7 to DI9	Digital input 7 to digital input 9	Photocoupler isolation, compatible with dual-polarity inputs Input impedance: 2.4 k Ω Voltage upon level input: 9 V to 30 V	See the preceding figure.
	24 V	External 24 VDC power terminal	Provides a +24 V power supply externally. Typically, this is used to power DI/DO terminals and external sensors. Maximum output current: 200 mA	
	OP1	Common terminal of multi-function input terminals	Internally isolated from the COM and 24 V terminals. The OP1 terminal is connected to the "24 V" terminal through jumper J8 at delivery. To use an external power supply, remove jumper J8 and connect OP1 to the external power supply.	
	CME	Common terminal of multi-function output terminals	-	



Mark		Terminal Name	Function Description	Terminal Arrangement
CN4	DI10	Digital input 10	Photocoupler isolation, compatible with dual-polarity inputs Input impedance: 2.4 k Ω Voltage upon level input: 9 V to 30 V	See the preceding figure.
	C485+ and C485-	RS485 communication port terminals	Modbus RTU communication input and output terminals; isolated input	
	CANH and CANL	CAN communication port terminals	CANlink communication input terminal; isolated input	
	COM	24 V reference ground	-	





Note



- The RS485 communication terminals 485+/485-/COM and CANlink communication terminals CANH/CANL/COM of the MD38IO1 card are completely independent from each other and can be used simultaneously.
- AC drives of models with the PLUS suffix come with the AI3 and AO2 terminals. The terminals of the same names on this expansion card cannot be used on those AC drives.

■ Jumpers

Table 1-2 MD38IO1 card jumpers

Mark	Terminal Name	Function Description	Jumper/DIP Switch Settings
J3	Jumper for setting the AO2 output type	Voltage type: 0 V to 10 V	
		Current type: 0 mA to 20 mA	
J7	COM	24 V reference ground	-
	CME	Common terminal of multi-function output terminals	-
	24 V	External 24 VDC power terminal	-
J8	24 V	External 24 VDC power terminal	-
	OP	Common terminal of multi-function input terminals	-
	COM	24 V reference ground	-

Mark	Terminal Name	Function Description	Jumper/DIP Switch Settings
S1	AI, PT100, or PT1000 function selection	AI3: Pins 1, 2, and 3 set to ON	
		PT1000: Pins 4, 5, and 6 set to ON	
		PT100: Pins 6, 7, and 8 set to ON	
S2	RS485 termination resistor selection	The termination resistor is connected when pins 1 and 2 are set to ON.	
		The termination resistor is disconnected when pins 1 and 2 are set to OFF.	

Mark	Terminal Name	Function Description	Jumper/DIP Switch Settings
S3	CAN termination resistor selection	The termination resistor is connected when pins 1 and 2 are set to ON.	
		The termination resistor is disconnected when pins 1 and 2 are set to OFF.	

Note

When the master and slave communication adopts the CAN protocol while the AC drive and display communication adopts the RS485 protocol, termination resistors on the first and last AC drive I/O1 expansion cards must be connected (through S3 and S2). In this case, keep the DIP switches on the intermediate AC drive I/O1 expansion cards in their factory default state.

2 Installation and Wiring

2.1 Installation

Note

Install the card only when the AC drive is completely de-energized.

Align the connector and positioning hole of the I/O expansion card with those on the AC drive control board. Fasten the card on the board with a screw.

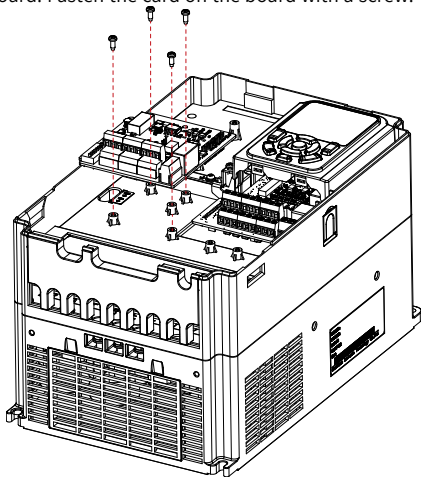

The installation is completed as shown in the following figure.

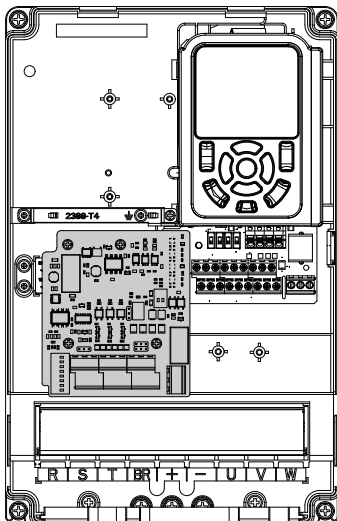

2.2 Wiring

■ DO terminal

To use the DO terminal to drive a relay, connect a snubber diode to both ends of the relay coil. Otherwise, the 24 VDC power supply may be damaged. Ensure that the driving capacity does not exceed 50 mA.

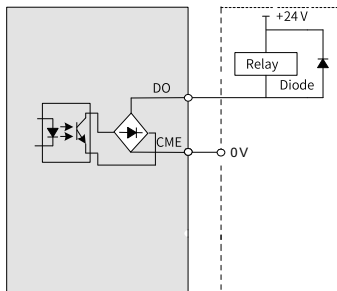



- If the snubber diode is not installed properly with correct polarity, the 24 VDC power supply will be damaged when the DO terminal is activated.
- When the digital output is powered by an external 24 V power supply, it is essential to verify whether the ground terminal of the external 24 V power supply can be connected to the CME terminal.

■ DI terminals

- Sink wiring

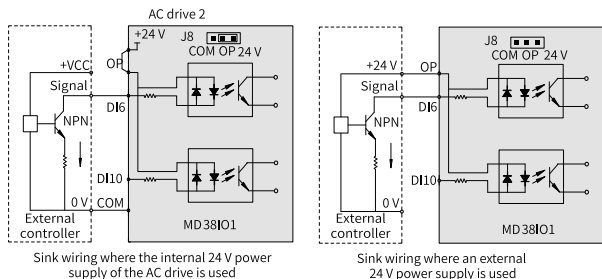

Figure 2-1 Sink wiring

Most commonly, the internal 24 V power supply of the AC drive is used to power the card. In this case, connect the OP terminal to the internal 24 V power supply, and connect the COM terminal of the AC drive to the 0 V terminal of the external controller.

To use an external 24 V power supply, connect the +24 V terminal of the external power supply to the OP terminal, and connect the 0 V terminal of the external power supply to the corresponding DI terminal through the contact of the controller.

Note

In the mode, the DIs of different AC drives cannot be connected in parallel. Otherwise, the DI may malfunction. If DIs of different AC drives must be connected in parallel, connect the anode of a diode to the DI in series and make the diode satisfy the requirement: $I_F > 40 \text{ mA}$ and $V_R > 40 \text{ V}$, as shown in “Figure 2-2 ” on page 18 .

The MD520 series AC drive is used as an example for illustration, as shown in “Figure 2-2 ” on page 18 .

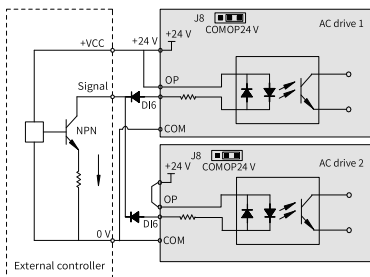

Figure 2-2 Sink wiring for parallel DI terminals of multiple AC drives (example)

- Source wiring

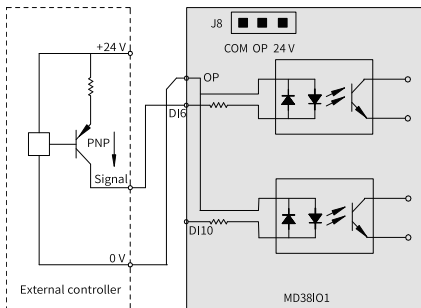

Figure 2-3 Source wiring

In source wiring, an external 24 V power supply is needed to power the card, as shown in “[Figure 2-3](#)” on page 19 . In this case, ensure that the external 0 V terminal is connected to the OP terminal.

■ AI terminal

The MD38IO1 expansion card is an accessory for the AC drive and should be used with the entire AC drive. The 10 V excitation shown in the following figure comes from the AC drive, as the expansion card does not provide that excitation source.

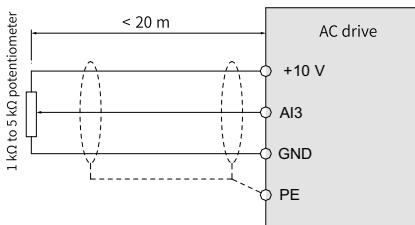

Figure 2-4 AI terminal wiring

■ RS485 communication bus use instructions

RS485 connection topology

The RS485 bus connection topology is shown in the figure below. It is recommended to use a shielded twisted pair cable as the RS485 bus, and use twisted pair cables to connect the RS485+ and RS485– terminals. Connect a 120 Ω termination resistor to

each end of the bus to prevent signal reflection. Set pins 1 and 2 of the switch S2 on the expansion card to ON to connect the termination resistor to the AC drive. Connect the RS485 reference ground of every node together. Up to 128 nodes can be connected. The length of each cable connecting a node to the bus must be less than 3 m.

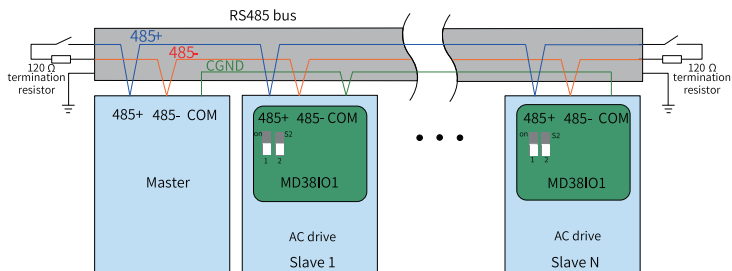

Figure 2-5 RS485 bus topology

Multi-node connection method

When there are a large number of nodes, the daisy chain topology must be used. If branch line connection is required, the length of the branch cable should be less than 3 m and as short as possible. Star connection is strictly prohibited. Common bus connection topologies are shown in the following figures.

Recommended  

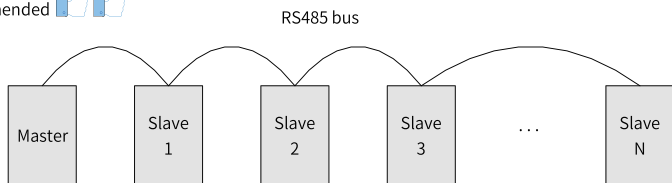



Figure 2-6 Daisy chain topology

Recommended 

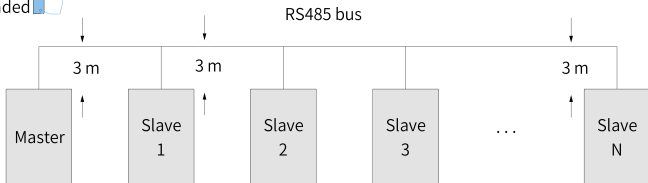

Figure 2-7 Branch line connection

Any branch cable should not exceed 3 m.

Prohibited 

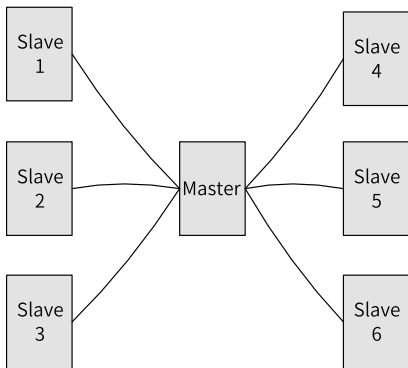

Figure 2-8 Star topology (prohibited)

■ Transmission distance and number of nodes

The following table lists the maximum number of nodes and transmission distance supported by the standard RS485 circuit at different transmission rates.

No.	Speed	Transmission Distance	Number of Nodes	Cable Size
1	115.2 kbps	100 m	128	26 AWG
2	19.2 kbps	1,000 m	128	26 AWG

■ Relay output terminal

Inductive loads (relays, contactors, and motors) cause voltage spikes at cutoff of current. To minimize such interference, connect a voltage dependent resistor to the relay contact. In addition, connect absorption circuits, such as voltage dependent resistors, RC absorption circuits, and diodes, to the inductive loads.

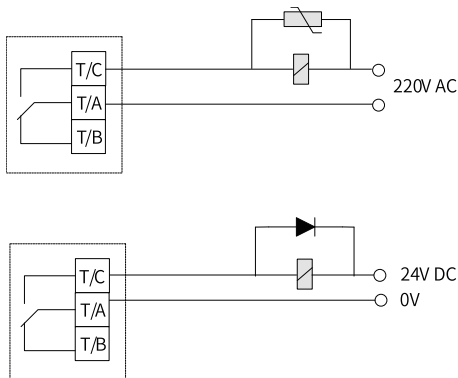
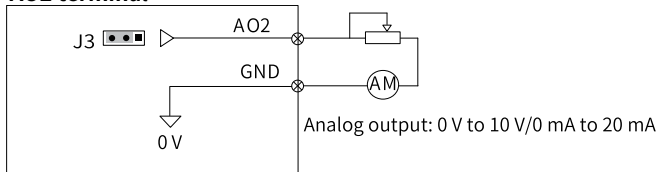

Figure 2-9 Anti-interference treatment for the relay output terminal

■ AO2 terminal



The AO2 terminal can be used to indicate internal operation parameters in analog form. The preceding figure illustrates how to connect the AO2 terminal to the AM

terminal of the display. For the AO2 terminal, pins 1 and 2 of jumper J3 are short-circuited by default, which enables the voltage mode. The output voltage range is 0 V to 10 V. Short-circuiting pins 2 and 3 of jumper J3 enables the current mode. The output current range is 0 mA to 20 mA.