

GPSSA, GPSS series

Ordering code

GPSS 6 01 A □
 ① ② ③ ④ ⑤

| ① Model | ② Port size | ③ Thread connection | | ④ Control method | ⑤ Standard color | |
|--|---|----------------------|---------------------------|---|---|---|
| GPSS: Universal speed controller(G thread) | 4: Φ4mm 6: Φ6mm 8: Φ8mm 10: Φ10mm 12: Φ12mm | Thread M5: M5X0.8 | Adaptable port size Φ4 | A: Meter-out Controlled flow Free flow B: Meter-in Free flow Controlled flow | Standard color Blank: Gray D: Black | Specification Release button: Gray Body: Gray Release button: Black Body: Black |

GPSSA 6 □

① ② ③

| ① Model | ② Port size | ③ Standard color | |
|----------------------------------|---|---|---|
| GPSSA: Straight speed controller | 4: Φ4mm 6: Φ6mm 8: Φ8mm 10: Φ10mm 12: Φ12mm | Standard color Blank: Gray D: Black | Specification Release button: Gray Body: Gray Release button: Black Body: Black |

Product feature

1. The silencer is small size, and light weight with small installation space.
2. Excellent flow characteristics, high sensitivity and easy to adjust.
3. The silencer brass body adopts a special nickel-plating process, which has good corrosion resistance and anti-pollution property.
4. Anti-drop structure is designed on the regulating rod.
5. The sealant being coated on threaded portion can ensure no leakage of the threaded connection part.
6. The inserting direction of universal speed controller can be adjusted in 360°.

Specification

| | |
|------------------------------------|---|
| Operating pressure range | 0~10kgf/cm²(0~1.0MPa) |
| Negative pressure | -750mmHg(10Torr) |
| Proof pressure | 1.5MPa |
| Ambient and fluid temperature (°C) | -20~70 |
| Applicable tubing | Soft nylon or polyurethane |
| Color | Gray/black |

Table for interface port and tube O.D.

| Product series | Thread type | Port size | | | | |
|----------------|-------------|-----------|----|----|-----|-----|
| | | Φ4 | Φ6 | Φ8 | Φ10 | Φ12 |
| GPSSA | - | ● | ● | ● | ● | ● |
| | M5 | ● | | | | |
| GPSS | G1/8 | | ● | ● | | |
| | G1/4 | | ● | ● | ● | |
| | G3/8 | | | | ● | ● |
| | G1/2 | | | | | ● |

Symbol

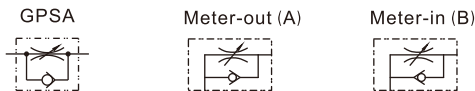

Inner structure

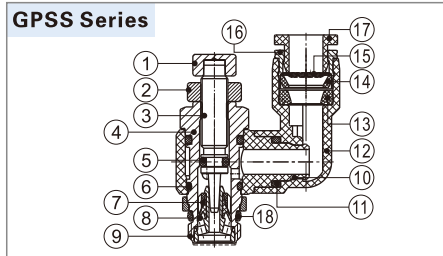
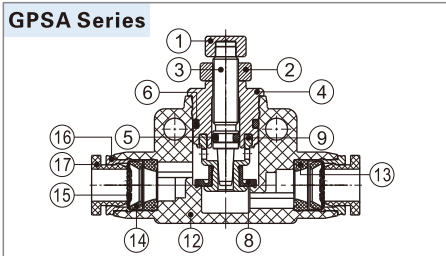

| NO. | Name | Material | NO. | Name | Material | NO. | Name | Material |
|-----|-------------------|----------------|-----|-------------------|----------------------|-----|-------------------|-----------------|
| 1 | Adjusting cap | Aluminum alloy | 7 | Holder | PBT | 13 | O-ring | NBR |
| 2 | Locking cap | Aluminum alloy | 8 | O-ring | NBR | 14 | Locating seat | POM |
| 3 | Throttling column | Brass | 9 | Throttling sleeve | Aluminum alloy/Brass | 15 | Spring gasket | Stainless steel |
| 4 | Throttling body | Brass | 10 | Plastic body | PBT | 16 | Locating ring | Aluminum alloy |
| 5 | O-ring | NBR | 11 | O-ring | NBR | 17 | Plastic interface | POM |
| 6 | O-ring | NBR | 12 | Plastic body | PBT | 18 | O-ring | NBR |

GPSSA, GPSS series

Dimensions

GPSS Series

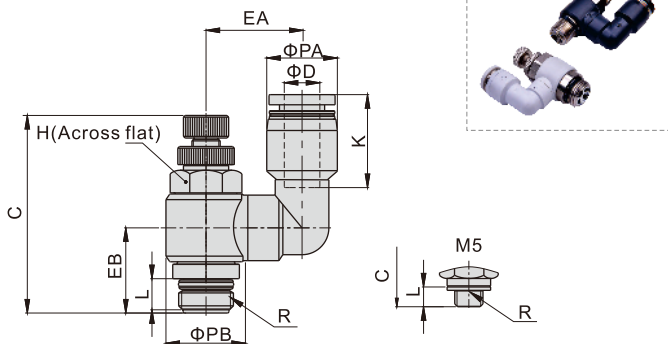

GPSSA Series

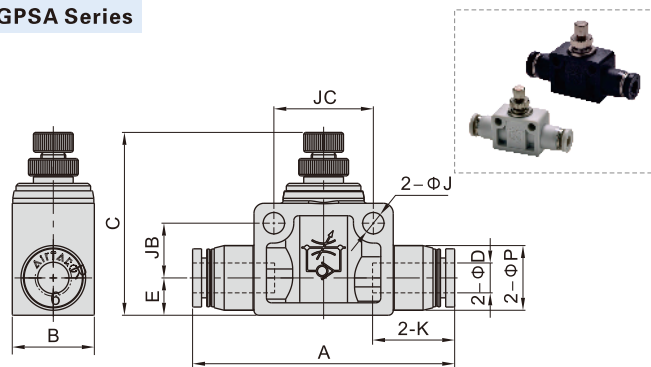

| Model/Item [Note1] | ΦD | R | ΦPA | ΦPB | L | C | | K | EA | EB | H | Weight (g) | PCS/bag |
|-----------------------|----|--------|------|------|-----|------|------|------|------|------|----|---------------|---------|
| | | | | | | max | min | | | | | | |
| GPSS4M5□ | 4 | M5×0.8 | 9 | 10 | 3.5 | 30 | 27.5 | 14 | 12.5 | 9.5 | 8 | 8.1 | 2 |
| GPSS601□ | 6 | G1/8 | 12.5 | 14 | 5.5 | 41.5 | 35 | 17 | 17 | 15 | 11 | 19 | 2 |
| GPSS602□ | | G1/4 | 12.5 | 18 | 6.5 | 47.5 | 41 | 17 | 19 | 17.5 | 14 | 34.7 | 2 |
| GPSS801□ | 8 | G1/8 | 15 | 14 | 5.5 | 41.5 | 35 | 18.5 | 17 | 15 | 11 | 20.2 | 2 |
| GPSS802□ | | G1/4 | 15 | 18 | 6.5 | 47.5 | 41 | 18.5 | 19 | 17.5 | 14 | 39.8 | 2 |
| GPSS1002□ | 10 | G1/4 | 18 | 18 | 6.5 | 47.5 | 41 | 21 | 20.5 | 17.5 | 14 | 37.2 | 2 |
| GPSS1003□ | | G3/8 | 18 | 22.5 | 7 | 52.5 | 45.5 | 21 | 24 | 20 | 19 | 66 | 2 |
| GPSS1203□ | 12 | G3/8 | 21 | 22.5 | 7 | 52.5 | 45.5 | 23 | 25.5 | 20 | 19 | 69.2 | 2 |
| GPSS1204□ | | G1/2 | 21 | 28 | 8.5 | 58.5 | 51.5 | 23 | 28 | 25 | 24 | 105.8 | 2 |

[Note1] "□" stands for A or B. A indicates meter-out type while B indicates meter-in type. The two types are with the same overall dimension.

| Model/Item | ΦD | A | B | C | | ΦP | E | K | ΦJ | JB | JC | Weight (g) | PCS/bag |
|------------|----|------|------|------|------|------|------|------|-----|------|----|---------------|---------|
| | | | | max | min | | | | | | | | |
| GPSSA4 | 4 | 41 | 11 | 29 | 26.5 | 9.5 | 7 | 14 | 3.2 | 6 | 14 | 7.85 | 2 |
| GPSSA6 | 6 | 52.5 | 16.5 | 43.5 | 36.5 | 13 | 7.5 | 16.5 | 4.3 | 11 | 20 | 18.3 | 2 |
| GPSSA8 | 8 | 59.5 | 16.5 | 47 | 40 | 15 | 8.5 | 18.5 | 4.3 | 11 | 22 | 23.5 | 2 |
| GPSSA10 | 10 | 69 | 21 | 53.5 | 46.5 | 18 | 10.5 | 21 | 4.3 | 14.5 | 26 | 42.4 | 2 |
| GPSSA12 | 12 | 78.5 | 26 | 58.5 | 51 | 21.5 | 12 | 23 | 4.3 | 17.5 | 32 | 67.5 | 2 |

GPSA, GPSS series

Flowrate characteristic

Controlled flow rate

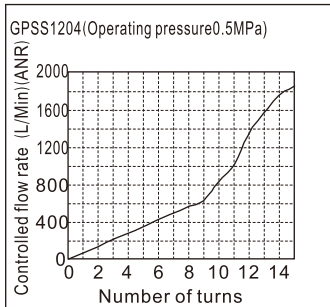
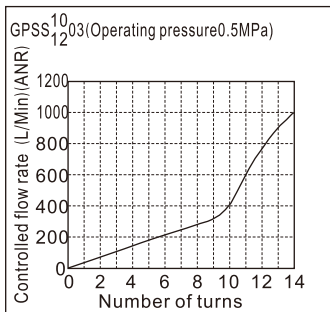
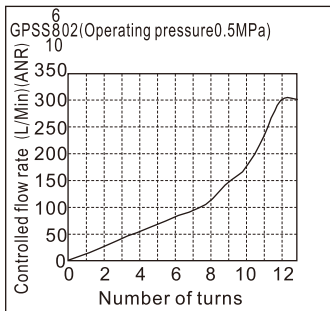
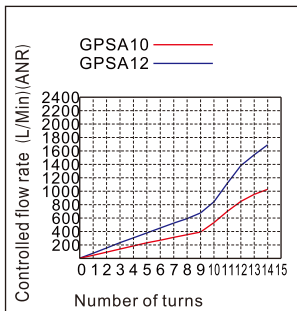
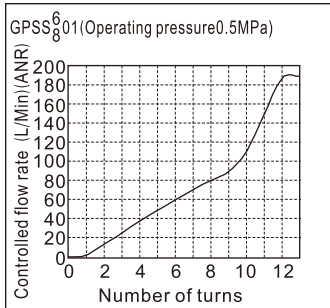
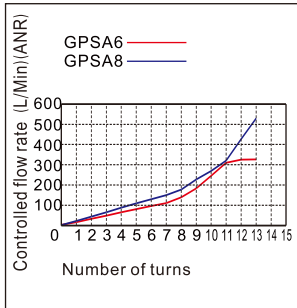
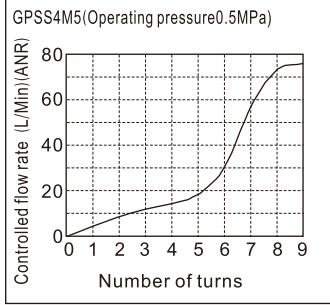
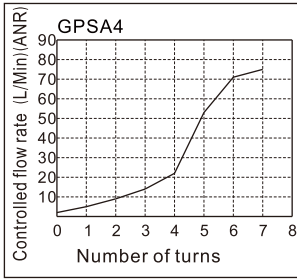

Free flow rate

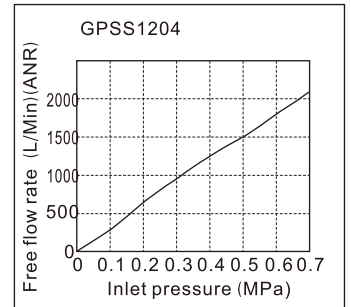
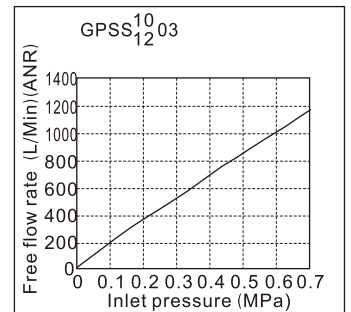
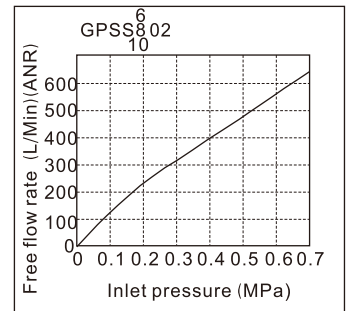
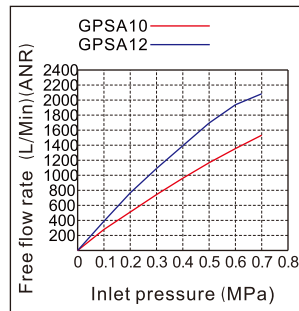
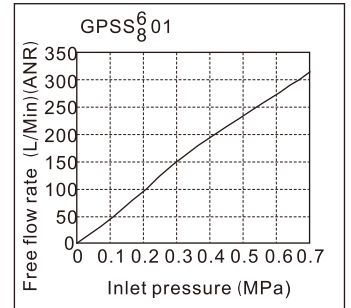
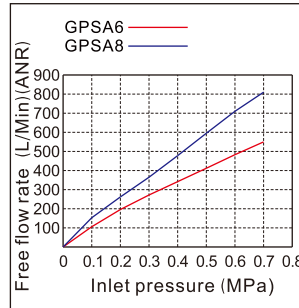
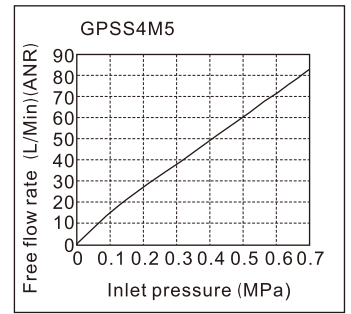
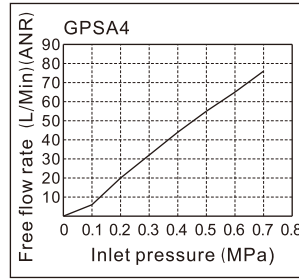

Selection, Installation and Operation

Selection

- The speed controller has meter-out type and meter-in type:

| | Working principle | Product identification |
|--------------------------------------|---|------------------------|
| <p>Controlled flow Free flow</p> | A: Meter-out 1. The air flow is controlled from the threaded end to tubing connection end. 2. The air flow is free from the tubing connection end to the threaded end. | Handle marking "A" |
| <p>Free flow Controlled flow</p> | B: Meter-in 1. The air flow is free from the threaded end to tubing connection end. 2. The air flow is controlled from the tubing connection end to the threaded end. | Handle marking "B" |

- Select the different control method according to the actual requirement. The meter-out type is the first priority.

2.1. The application example of the meter-out speed controller | 2.2. The application example of the meter-in speed controller



Installation

- Installation and removal of tubing:

- 1.1. Installation of tubing

Grasp the tubing and slowly push it into the fitting until it comes to a stop. The tubing will be locked by the spring gasket.

- 1.2. Removal of tubing

Push the release button to open the spring gasket so that the tubing can be released.

Note: When remove the tubing, make sure the pressure in the tubing is Zero.

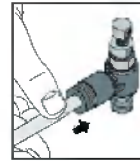

2. Mounting of the speed controller

Mount the speed controller into the inlet and outlet port of the cylinder with a wrench.

Note: Please refer to the fittings for the tightening torque and thread screw-in depth.

Operation

1. Adjustment of the cylinder speed

1.1. Make sure the speed controller is turned off before applying air pressure. The cylinder may fly out due to the high speed if the air is inlet when the speed controller is turned on.

1.2. Adjust the speed by opening the needle slowly from the fully closed state. When a needle valve is turned clockwise, the air flow through is reduced and the actuator speed decreases. When a needle valve is turned counter-clockwise, the air flow through is increased and the actuator speed increases.

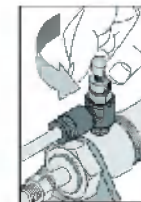
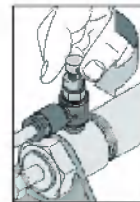

2. Operation of the speed controller

2.1. Do not use tools such as pliers to rotate the handle. Do not apply excessive force or shock when the needle is at the place of top or bottom. It can cause damage or air leakage.

2.2. A certain amount of leakage is allowed in the closed state of the speed controller. It is not designed for the use as stop valve with zero air leakage.