

Air valve(5/2 way, 5/3 way)

4A300 Series



Specification

Model	4A310-08 4A320-08	4A330C-08 4A330E-08 4A330P-08	4A310-10 4A320-10	4A330C-10 4A330E-10 4A330P-10
Fluid	Air(to be filtered by 40 μm filter element)			
Acting	Exterior control			
Port size [Note1]	In=Out=Exhaust=1/4"		In=Out=3/8" Exhaust=1/4"	
Orifice size(Cv) [Note4]	4A310-10,4A320-10:28.0mm ² (Cv=1.65) 4A330C-10:21.3mm ² (Cv=1.25)			
Valve type	5 port 2 position	5 port 3 position	5 port 2 position	5 port 3 position
Operating pressure	0.15~0.8MPa(21~114psi)			
Proof pressure	1.2MPa(175psi)			
Temperature	-20~70°C			
Material of body	Aluminum alloy			
Lubrication [Note2]	Not required			
Max. frequency [Note3]	4 cycle/sec	3 cycle/sec	4 cycle/sec	3 cycle/sec
Weight (g)	4A310-08:275 4A320-08:365	505	4A310-10:275 4A320-10:365	505

Symbol

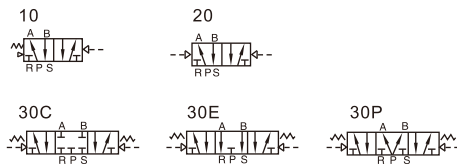

[Note1] G thread is available.

[Note2] Once lubricated air is used, continue with same medium to optimise valve life span. Lubricants like ISO VG32 or equivalent are recommended.

[Note3] The maximum actuation frequency of no-load state.

[Note4] Equivalent orifice S and Cv are all calculated from the flow rate data.

Product feature

- Structure in sliding column mode: good tightness and sensitive reaction.
- Three position air valves have three kinds of central function for your choice.
- Double air control valves have memory function.
- Internal hole adopts special processing technology which has little attrition friction, low start pressure and long service life.
- No need to add oil for lubrication.
- Integrate with the manifold to save installation space.

Ordering code

4A 3 10 10 G



① Model	② Code	③ Valve type	④ Port size	⑤ Thread type
4A: Air Valve(5/2, 5/3 way)	3: 300 Series	10: Single air control 5/2 way 20: Double air control 5/2 way 30C: Double air control 5/3 way closed center 30E: Double air control 5/3 way exhaust center 30P: Double air control 5/3 way pressure center	08: 1/4" 10: 3/8"	G: G Thread

Please refer to 115 for manifold specification and the order way.

Flow chart

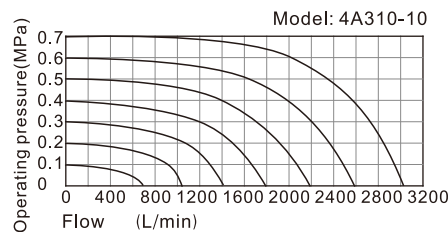

The data in flow rate chart are obtained from AirTAC lab.

Air valve(5/2 way, 5/3 way)

4A300 Series

Inner structure

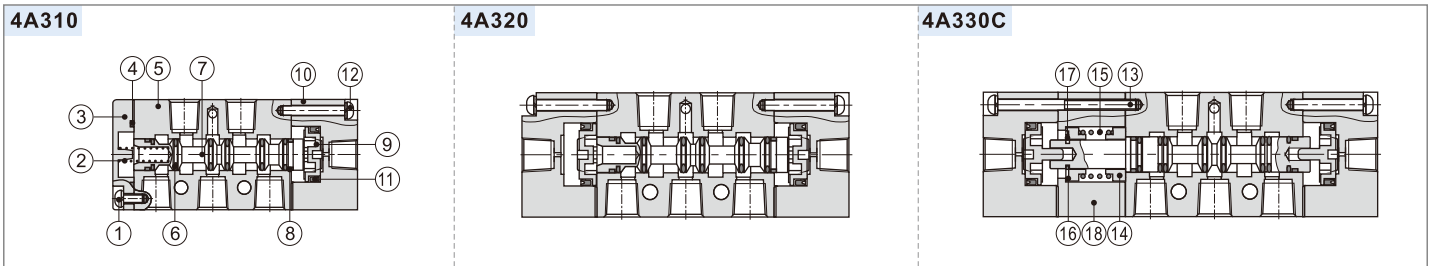

No.	Item	No.	Item	No.	Item	No.	Item	No.	Item	No.	Item	No.	Item	No.	Item	No.	Item
1	Screw	3	Bottom cover	5	Body	7	Spool	9	Piston	11	O-ring	13	Screw	15	Return Spring	17	E Clip
2	Spring	4	Bottom cover gasket	6	O-ring	8	Wear ring	10	Pilot body	12	Screw	14	Spring holder	16	Spring holder	18	Side cover

Dimension

4A310

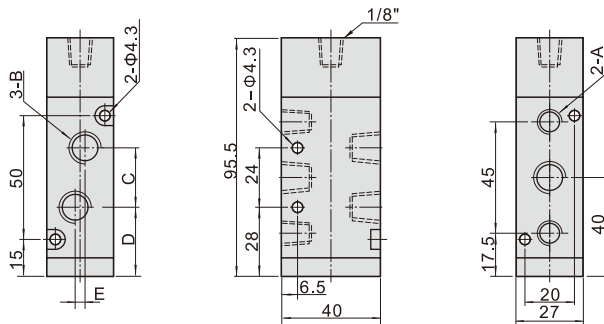

Model\Item	A	B	C	D	E
4A310-08	1/4"	1/4"	22	29	0
4A310-10	1/4"	3/8"	24	28	4

4A320

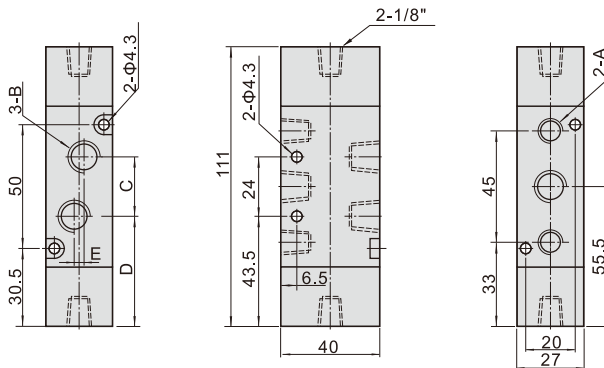

Model\Item	A	B	C	D	E
4A320-08	1/4"	1/4"	22	44.5	0
4A320-10	1/4"	3/8"	24	43.5	4

4A330

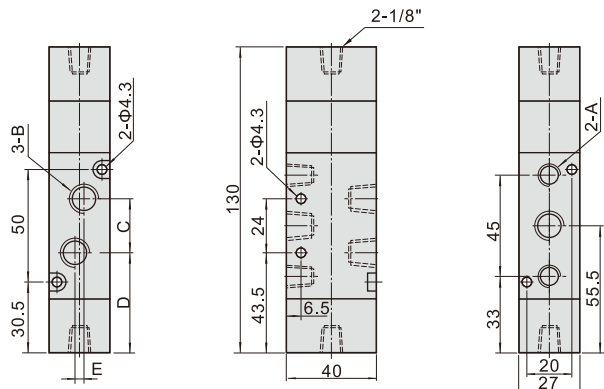

Model\Item	A	B	C	D	E
4A330-08	1/4"	1/4"	22	44.5	0
4A330-10	1/4"	3/8"	24	43.5	4