

Fluid control valve(2/2 way)



2LA Series (Direct-acting and normally closed)



Symbol



Product feature

1. Direct acting and normally closed type 2/2 way solenoid valve. Its high sensibility allows it to change direction quickly;
2. It has wide pressure range, including standard high pressure (H) to choose from;
3. It is compact, small size and light weight. It is easy to install and dismantle.
4. The valve body is made of SUS304 . Its coil has a Heat resistance classification of Class H. The standard seal material is PTFE(Teflon) which is suitable for a variety of working medium such as water with high temperature and vapour.
5. The protection class of the coil is IP65 and there is a choice for grommet or terminal electrical entry .

Inner structure

2LA030 (Terminal)

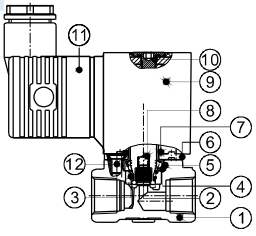

No.	Item	No.	Item	No.	Item
1	Body	5	O-ring	9	Coil assembly
2	Airtight ring	6	Fixed plate	10	Bolt
3	Spring	7	Gasket washer	11	Connector
4	Steel bushing	8	Movable core	12	Screw

Specification

Model/Item	Port size [Note1]	Orifice size (Φmm)	Cv	Valid area or section (mm ²)	Weight [Note2](g)	Max.operating pressure differential		Proof pressure	
						MPa	psi	MPa	psi
2LAH030	-06 1/8"	2.0	0.18	3.0	244.5	2.0	300	3.0	450
	-08 1/4"								
2LA030	-06 1/8"	3.0	0.33	6.0	244.5	1.0	150		
	-08 1/4"								
2LAH050	-10 3/8"	4.0	0.55	10.0	529	2.0	300		
	-15 1/2"								
2LA050	-10 3/8"	5.0	0.83	15.0	529	1.0	150		
	-15 1/2"							509	

[Note1] G thread is available.

[Note2] The weight in the table is the terminal valve's weight, 2LA030 series grommet valve's weight is 10g less than terminal's. 2LA050series grommet valve's weight is 20g less than terminal's.

Specification of coil

Valve type	Coil type	Power type	Frequency (Hz)	Voltage range	Electrical entry	Power Consumption (VA/W)	Insulation	Temp. rise(°C)
2LA□030	CDA110H CLA110H	AC	50	±15%	Terminal (CDA)	10.0VA	Class H	50
			60			8.0VA		45
		DC	-	±10%		6.5W		50
2LA□050	CDA160H CLA160H	AC	50	±15%	Grommet (CLA)	25.0VA		65
			60			±10%		22.0VA
		DC	-	±10%		12.0W		50

Valve's specification

Acting		Direct acting			
Initial state		Normally closed			
Adaptable fluid		Steam, High temperature Water, Oil			
Viscosity limit		Under 20CST			
Ambient and fluid temperature (°C)	Max.	Oil 150	Water 150	Steam 183	Ambient 100
	Min.	-10 [Note1]	1	-	-20

[Note1] 50CST or less.

Ordering code

Ordering code of valves

2LA H 030 08 A □ □

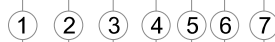

① Model	② Pressure condition	③ Size series	④ Port size	⑤ Voltage	⑥ Electrical entry	⑦ Thread type
2LA: 2/2 way direct-acting and normally closed	H: High pressure Blank: Standard	030: 030 Series 050: 050 Series	06: 1/8" 08: 1/4" 10: 3/8" 15: 1/2"	A: AC220V B: DC24V C: AC110V E: AC24V F: DC12V	Blank: Terminal I: Grommet[Note]	G: G

[Note] The wire length is 0.5m.

Ordering code of accessories

Ordering code of accessories is the same as 2WA series valve's, Please refer to P169 for details of ordering code.



Fluid control valve(2/2 way)

2LA Series (Direct-acting and normally closed)



Flow chart

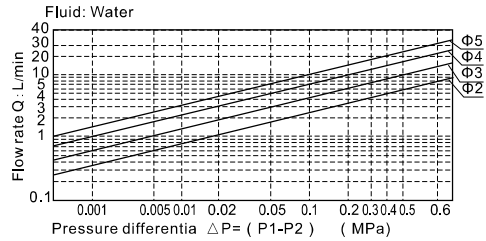
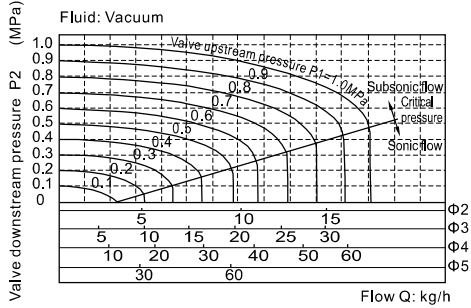

Dimensions

2LA□030(Terminal)

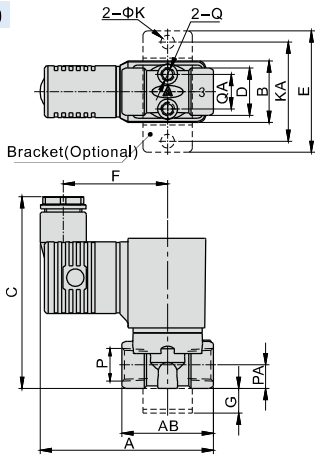

2LA□030(Grommet)

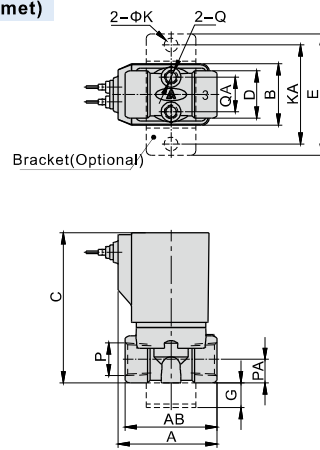

2LA□050(Terminal)

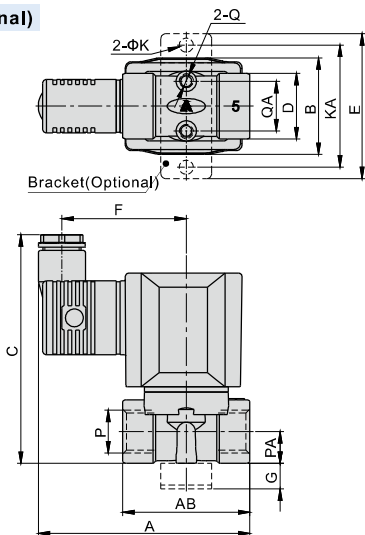

2LA□050(Grommet)

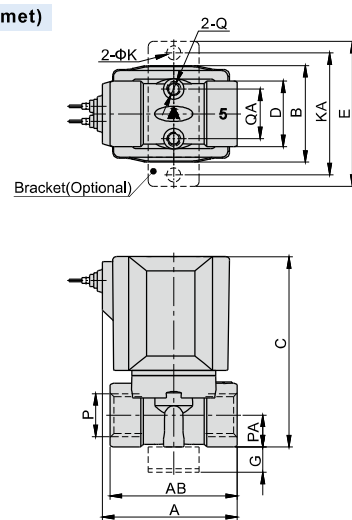

Model\Item	A	AB	B	C	D	E	F	G	K	KA	P	PA	Q	QA
2LA□030-06	70	37	25	77.5	19	49	42	10	5.5	40	1/8"	9.5	M5	13.5
2LA□030-08	70	37	25	77.5	19	49	42	10	5.5	40	1/4"	9.5	M5	13.5
2LA□050-10	83	50	38	90	26	57	49	10	5.5	48	3/8"	12.5	M5	19.5
2LA□050-15	83	50	38	90	26	57	49	10	5.5	48	1/2"	12.5	M5	19.5

Model\Item	A	AB	B	C	D	E	G	K	KA	P	PA	Q	QA
2LA□030-06	40	37	25	61	19	49	10	5.5	40	PT1/8	9.5	M5	13.5
2LA□030-08	40	37	25	61	19	49	10	5.5	40	PT1/4	9.5	M5	13.5
2LA□050-10	53	50	38	78	26	57	10	5.5	48	PT3/8	12.5	M5	19.5
2LA□050-15	53	50	38	78	26	57	10	5.5	48	PT1/2	12.5	M5	19.5



Fluid control valve(2/2 way)



2LA Series (Internally piloted and normally closed)



Symbol



Product feature

1. Indirect acting (Internal pilot) and normally closed type 2/2 way solenoid valve. Its high sensibility allows it to change direction quickly.
2. It is compact, small size and light weight. It is easy to install and dismantle.
3. The valve body is made of SUS304. Its coil has a Heat resistance classification of Class H. The standard seal material is PTFE (Teflon) which is suitable for a variety of working medium such as water with high temperature and vapour.
4. The protection class of the coil is IP65 and there is a choice for grommet or terminal electrical entry.

Inner structure

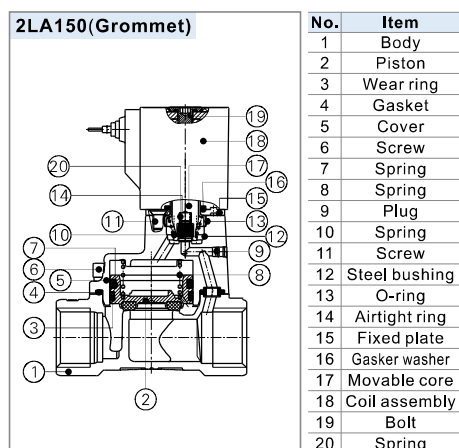

Specification

Model\Item	Port size [Note1]	Orifice size (Φmm)	Cv	Valid area or section (mm ²)	Weight [Note2](g)	Operating pressure differential		Proof pressure	
						MPa	psi	MPa	psi
2LA150-15	1/2"	15.0	5.50	100.0	570	Max:0.7 Min:0.05	Max:100 Min:10	1.5	220
2LA200-20	3/4"	20.0	9.50	170.0	723				
2LA250-25	1"	25.0	12.50	220.0	1027				
2LA320-32	1 1/4"	35.0	23.00	420.0	2262				
2LA400-40	1 1/2"	40.0	31.00	560.0	2642				
2LA500-50	2"	50.0	49.00	880.0	3509				

[Note1] G thread is available.

[Note2] The weight in the table is the terminal valve's weight, 2LA150~250series grommet valve's weight is 10g less than terminal's. 2LA320~500series grommet valve's weight is 20g less than terminal's.

Specification of coil

Valve type	Coil type	Power type	Frequency (Hz)	Voltage range	Electrical entry	Power Consumption (VA/W)	Insulation	Temp. rise(°C)
2LA150 2LA200 2LA250	CDA110H CLA110H	AC	50	± 15%	Terminal (CDA)	10.0VA	Class H	50
			60			8.0VA		45
	DC	-	± 10%	6.5W		50		
2LA320 2LA400 2LA500	CDA160H CLA160H	AC	50	± 15%	Grommet (CLA)	25.0VA		65
			60			22.0VA		60
	DC	-	± 10%	12.0W		50		

Valve's specification

Acting	Internally piloted				
Initial state	Normally closed				
Adaptable fluid	Steam, High temperature Water, Oil				
Viscosity limit	Under 20CST				
Ambient and fluid temperature (°C)		Oil	Water	Steam	Ambient
	Max.	150	150	183	100
Min.	-10 [Note1]	1	-	-	-20

[Note1] 50CST or less.

Ordering code

Ordering code of valves

① Model	② Orifice size	③ Port size	④ Voltage	⑤ Electrical entry	⑥ Thread type
2LA: 2/2 way internally piloted and normally closed	150: Φ15mm	15: 1/2"	A: AC220V B: DC24V C: AC110V E: AC24V F: DC12V	Blank: Terminal I: Grommet[Note]	G: G
	200: Φ20mm	20: 3/4"			
	250: Φ25mm	25: 1"			
	320: Φ35mm	32: 1 1/4"			
	400: Φ40mm	40: 1 1/2"			
	500: Φ50mm	50: 2"			

[Note] The wire length is 0.5m.

Ordering code of accessories

Ordering code of accessories is the same as 2WA series valve's, please refer to P171 for details of ordering code.

[Note] 320\400\500 series valves do not have mounting accessories.



Fluid control valve(2/2 way)



2LA Series (Internally piloted and normally closed)

Flow chart

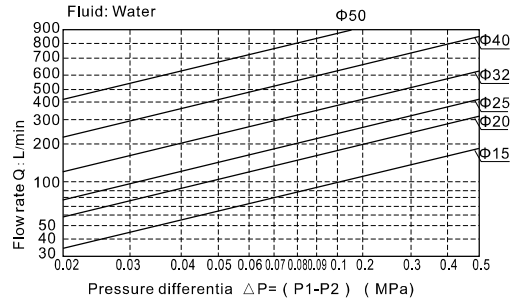
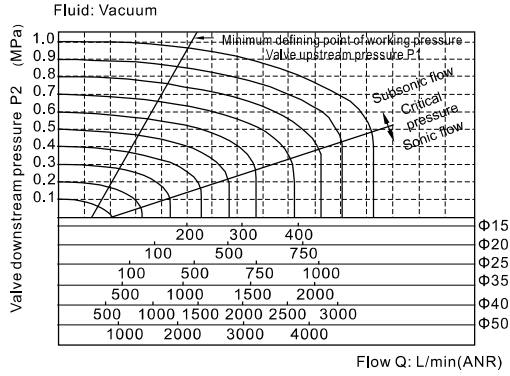

Dimensions

2LA150~250(Terminal)

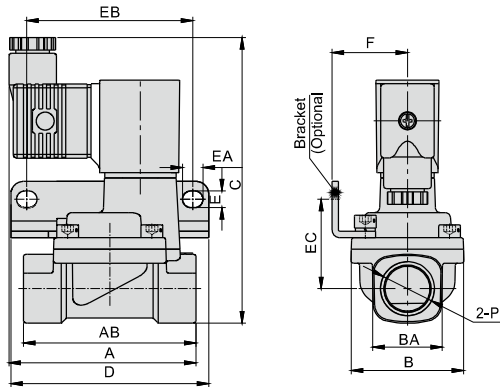

2LA150~250(Grommet)

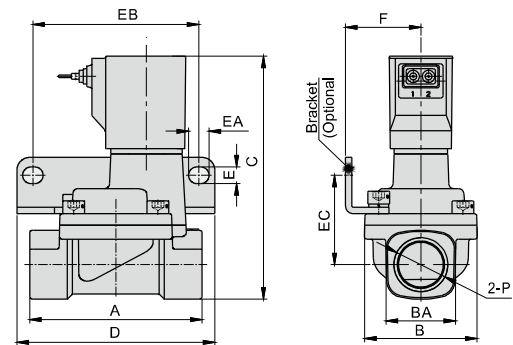

2LA320~500(Terminal)

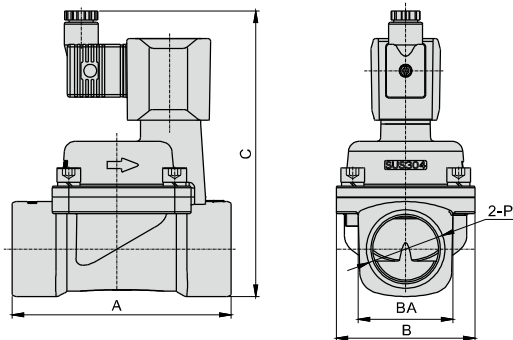

2LA320~500(Grommet)

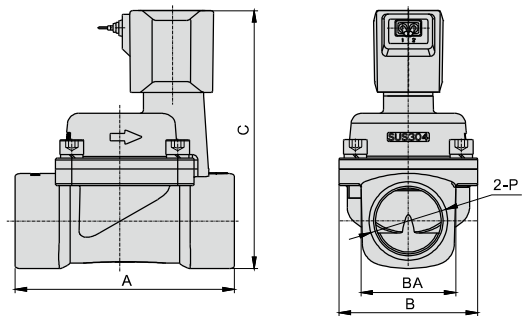

Model/Item	A	AB	B	BA	C	D	E	EA	EB	EC	F	P
2LA150-15	73.5	67.5	44	27.5	112	77.5	6.5	8	65	35	29.5	1/2"
2LA200-20	75.5	79.5	51	33.5	119	87.5	6.5	8	75	38	33	3/4"
2LA250-25	77.5	90	57	40.5	126	93	6.5	8	80	42	35	1"
2LA320-32	120	-	76	52	156	-	-	-	-	-	-	1 1/4"
2LA400-40	126	-	86	58	166	-	-	-	-	-	-	1 1/2"
2LA500-50	144	-	96	70	177	-	-	-	-	-	-	2"

Model/Item	A	B	BA	C	D	E	EA	EB	EC	F	P
2LA150-15	67.5	44	27.5	96	77.5	6.5	8	65	35	29.5	PT1/2
2LA200-20	79.5	51	33.5	103	87.5	6.5	8	75	38	33	PT3/4
2LA250-25	90	57	40.5	110	93	6.5	8	80	42	35	PT1
2LA320-32	120	76	52	143	-	-	-	-	-	-	PT1 1/4
2LA400-40	126	86	58	152	-	-	-	-	-	-	PT1 1/2
2LA500-50	144	96	70	167	-	-	-	-	-	-	PT2

